

**special issue**  
2023july

 **ENGINSOFT**

# futurities

The Simulation Based Engineering & Sciences Magazine

**Additive  
Manufacturing**

## Futurities

### Special Issue 2023 - Additive Manufacturing

To receive a free copy of the next magazine, please contact our Marketing office at: [marketing@enginsoft.com](mailto:marketing@enginsoft.com)

*All pictures are protected by copyright. Any reproduction of these pictures in any media and by any means is forbidden unless written authorization by EnginSoft has been obtained beforehand. ©Copyright EnginSoft.*

#### EnginSoft S.p.A.

24126 BERGAMO c/o Parco Scientifico Tecnologico  
Kilometro Rosso - Edificio A1, Via Stezzano 87 • Tel. +39 035 368711  
50127 FIRENZE Via Panciattichi, 40 • Tel. +39 055 4376113  
35129 PADOVA Via Giambellino, 7 • Tel. +39 049 7705311  
72023 MESAGNE (BRINDISI) Via A. Murri, 2 - Z.I. • Tel. +39 0831 730194  
38123 TRENTO fraz. Mattarello - Via della Stazione, 27 • Tel. +39 0461 915391  
10133 TORINO Corso Marconi, 20 • Tel. +39 011 6525211

[www.enginsoft.com](http://www.enginsoft.com)

e-mail: [info@enginsoft.com](mailto:info@enginsoft.com)

*Futurities is a quarterly magazine published by EnginSoft SpA*

#### COMPANY INTERESTS

EnginSoft GmbH - Germany  
EnginSoft UK - United Kingdom  
EnginSoft Turkey - Turkey  
EnginSoft USA  
Particleworks Europe  
[www.enginsoft.com](http://www.enginsoft.com)

CONSORZIO TCN [www.consorziotcn.it](http://www.consorziotcn.it) • [www.improve.it](http://www.improve.it)  
M3E Mathematical Methods and Models for Engineering [www.m3eweb.it](http://www.m3eweb.it)  
AnteMotion [antemotion.com](http://antemotion.com)

#### ASSOCIATION INTERESTS

NAFEMS International [www.nafems.it](http://www.nafems.it) • [www.nafems.org](http://www.nafems.org)  
TechNet Alliance [www.technet-alliance.com](http://www.technet-alliance.com)

#### ADVERTISING

For advertising opportunities, please contact our Marketing office at: [marketing@enginsoft.com](mailto:marketing@enginsoft.com)

#### RESPONSIBLE DIRECTOR

Stefano Odorizzi

#### PRINTING

Grafiche Dalpiaz - Trento

Autorizzazione del Tribunale di Trento  
n° 1353 RS di data 2/4/2008

The *Futurities* editions contain references to the following products which are trademarks or registered trademarks of their respective owners:

**Ansys**, **Ansys Workbench**, **AUTODYN**, **CFX**, **Fluent**, **Forte**, **SpaceClaim** and any and all Ansys, Inc. brand, product, service and feature names, logos and slogans are registered trademarks or trademarks of Ansys, Inc. or its subsidiaries in the United States or other countries. [ICEM CFD is a trademark used by Ansys, Inc. under license] ([www.ansys.com](http://www.ansys.com)) - **modeFRONTIER** is a trademark of ESTECO Spa ([www.esteco.com](http://www.esteco.com)) - **Flownex** is a registered trademark of M-Tech Industrial - South Africa ([www.flownex.com](http://www.flownex.com)) - **MAGMASOFT** is a trademark of MAGMA GmbH ([www.magmasoft.de](http://www.magmasoft.de)) - **LS-DYNA** is a trademark of LSTC ([www.lstc.com](http://www.lstc.com)) - **Cetol 6σ** is a trademark of Sigmatrix L.L.C. ([www.sigmatrix.com](http://www.sigmatrix.com)) - **RecurDyn™** and **MBD for Ansys** is a registered trademark of FunctionBay, Inc. ([www.functionbay.org](http://www.functionbay.org)) - **Maplesoft** is a trademark of Maplesoft™, a subsidiary of Cybernet Systems Co. Ltd. in Japan ([www.maplesoft.com](http://www.maplesoft.com)) - **Particleworks** is a trademark of Prometech Software, Inc. ([www.prometechsoftware.com](http://www.prometechsoftware.com)). **Multiscale.Sim** is an add-in tool developed by CYBERNET SYSTEMS CO.,LTD., Japan for the Ansys Workbench environment - **Rocky** is a trademark of ESSS ([www.esss.co](http://www.esss.co)) - **industrialPhysics** is a trademark of Machineering GmbH ([www.machineering.com](http://www.machineering.com)) - **SIMUL8** is a trademark of SIMUL8 Corporation ([www.simul8.com](http://www.simul8.com)) - **ViveLab Ergo** is a trademark of ViveLab Ergo Ltd. ([www.vivelab.cloud](http://www.vivelab.cloud)) - **True-Load** is a trademark of Wolf Star Technologies ([www.wolfstartech.com](http://www.wolfstartech.com))



# Contents



4 Additive Manufacturing (AM) and big industry: the state of play and a glimpse of the future  
*by EnginSoft*



8 A review of the manufacturing technologies and characteristics of metal powders for additive manufacturing  
*by Pometon, MIMETE*

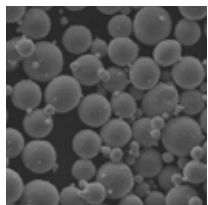

11 The importance of knowing metal powders' properties and process effects in additive manufacturing  
*by University of Modena and Reggio Emilia*



15 L-PBF additive manufacturing simulation of a "cold crucible" in copper alloy  
*by EnginSoft, Addtoshape*



20 Optimization of the SLM/DMLS process to manufacture an aerodynamic Formula 1 part  
*by EnginSoft, Università degli Studi di Modena e Reggio Emilia, ADDITIVA*



24 Design and impact assessment of a die-casting insert made with Additive Manufacturing  
*by Saen, Università degli Studi di Padova, EnginSoft*



32 Tita-Banti's Olympic catamaran keeps flying thanks to 3D printing from the ProM Facility  
*by Trentino Sviluppo*



34 The power of liquid media for finishing 3D-printed metal parts  
*by RENA Technologies Austria*

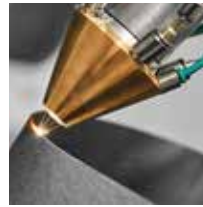

36 Simulation and integration of a DED repair pipeline into the machine tool control environment  
*by EnginSoft*



40 Soft shaping of hard metals  
*by RHP Technology*



44 Think big: XXL 3D printed titanium structures for space  
*by SBI*



47 Lithography-based ceramic manufacturing: the industry standard for mass production with ceramic 3D printing  
*by Lithoz*



50 Heat exchanger optimization using additive manufacturing, simulation, CT inspection, and testing  
*by Synopsys*



54 Using HPC tools to optimize 3D-printing of orthopaedic devices  
*by CastPrint, University of Latvia, Riga Technical University*



56 DISTech's 3D printed metal parts revolutionize hydropulse impeller systems for electric boats using a process monitoring system developed in-house  
*by DISTech Group, Stroka Produkt, Hydro Impulse Systems, Balmar*



59 Enhancing quality assurance in additive manufacturing: harnessing the power of industrial computed tomography  
*by TEC Eurolab*



64 How to increase the competitiveness of startups in the AM space: macroeconomic development  
*by AM Ventures*

# face to face with Johannes Gartner

VP of Additive Manufacturing Austria



## Additive Manufacturing (AM) and big industry: the state of play and a glimpse of the future

by Kathleen Grant, EnginSoft

Research<sup>1</sup> published last year by Statista predicts that 3D technology will be a highly disruptive force for global manufacturing, with the emphasis shifting from the production of prototypes to full-scale manufacturing of parts and accessories. Statista's research states that AM will enable finished products to be manufactured on a large scale by 2030. Given its growing importance, Futurities decided to dedicate its "Spotlight" to exploring the different facets of this production disruptor, beginning with this interview with Johannes Gartner, VP of Additive Manufacturing Austria.

### References

[1] [www.statista.com/statistics/560323/worldwide-survey-3d-printing-top-technologies](https://www.statista.com/statistics/560323/worldwide-survey-3d-printing-top-technologies)



Many think that simulation should be a competitor to AM, yet it isn't; it is facilitative and supportive. The need to create prototypes before the physical realization of new products is greater than ever.

### Q. Can you give us an overview of the Additive Manufacturing approach at present?

A. Additive manufacturing (AM) is not one homogenous technology – it is a production paradigm, similar to subtractive manufacturing (that removes materials from a whole block to shape a certain structure or product by means of drilling, milling, or planing) or to forming manufacturing (that uses heat and/or pressure i.e. moulding, bending, and pressing to shape a structure).

The ISO and ASTM standards organizations currently define additive manufacturing simply as “a process of joining materials to make objects from 3D model data, usually layer upon layer, as opposed to subtractive manufacturing methodologies”.

There are currently at least seven basic processes defined by the ISO and ASTM to combine, melt, sinter, polymerize and bind materials. Beneath each of these processes are multiple companies offering different technological solutions which results in a wide variety of niche technologies all being gathered under the umbrella title of AM.

When the public thinks of additive manufacturing many have simple consumer devices (based on fused lamination) in mind and believe that it is quite a recent technology. However, the first AM technology, stereolithography, was already invented in the mid-80s by Chuck Hull from 3D Systems. He successfully combined technologies of the time – UV lasers, optics, and photopolymers – into a clever mechatronic system to create the first additive process. Many other techniques followed and were initially mainly used to produce prototypes for some industries like automotive but didn't attract much public attention.

The “niche” AM technology businesses with their high margins and patent protection created significant barriers to entry to the market for a long time, but that started changing when an open-source version of the expired fused deposition modelling (FDM) patent was published by the British engineer, Adrian Bowyer. The project, called RepRap, was welcomed by the maker community and led to the creation of many startups, attracting a lot of attention and resulting in some over-expectations. A kind of 3D printing hype peaked around 2013 as the market wasn't ready to support so many manufacturers. However, the interest and motivation around these technologies continued and has led to much riper technologies and many applications.

While the AM market, currently estimated at US\$15.2 billion (Wohlers Report 2022), is still minor compared to traditional manufacturing, it has been growing in two-digit percentages year after year for the last 20 years. It therefore bears all the indicators of a very disruptive technology.

### Q. What are some of the most interesting application areas at present?

A. There are applications for Additive Manufacturing at all levels of research, development and production across a variety of industries

– from food and biomedicine, to dental, automotive and aerospace. The most exciting areas of development can currently be found in the industrial and medical industries and involve the use of a variety of materials – polymers, metals, ceramics and compounds. This opens up new opportunities for the traditional metal or polymer industries i.e. through the creation/addition of fibre-reinforced polymers or ceramic elements. As a result, we are now seeing an increased blurring of borders between traditional material silos.

### Q. What are the most important advantages and benefits of AM?

A. Additive processes offer the ability to produce extraordinarily complex, intertwined, or inner structures that are impossible to mill or mould. In this space, AM is already being used, for instance, to create lightweight structures to achieve up to 60% less weight with greater durability (as an example of this, see GE Aviation using AM to produce lightweight parts for Boeing and Airbus). Even if the production cost might be a bit more expensive at first, the fuel savings or greater efficiency offset these costs.

Another huge advantage of AM, considered as a form of digital production, is its ability to produce individualized parts to achieve high customization. In a fully automated process based on digital 3D models it is irrelevant whether 100 identical parts or 100 distinct parts are produced.

### Q. Can you give us some examples of how AM is disrupting various sectors?

A. There are some very disruptive AM business models in the industrial and medical sectors, and there are also many promising experimental and research applications. One area where we are seeing massive adoption of AM to generate complex and highly customized parts is in the medical sector – for instance in the dental implants, prosthetics, and prostheses industries.



Courtesy of Lithoz

One prominent example is Invisalign, a form of transparent braces for teeth. This fully customized product has some specific advantages for patients, while benefitting economically from a highly digitized production chain. Such digitally supported individualized medical treatment offer the potential to reduce prices for consumers and medical insurers/public health providers.

A comparable disruptive application in the medical sphere can be found in the area of hearing aids: by taking a 3D scan of the inner ear, a unique inner ear shell can be automatically generated and printed for a perfect fit.

So, wherever business models are able to combine automation and individualization an attractive business case can arise. In addition, it is expected that as the technology becomes more widespread, economies of scale will come into effect and machine and material costs will fall.

### **Q. What are some of the bottlenecks affecting the adoption of AM by industry?**

A. One of the major bottlenecks around the adoption of AM, in my opinion, is that many engineers are currently still trained on traditional manufacturing technologies that have more limitations.

As AM offers more freedom of design, a kind of additive thinking approach is required to completely rethink products that have been optimized for other manufacturing principles. This requires a change in the education and training of engineers.

### **Q. What is the connection between simulation and AM?**

A. Many think that simulation should be a competitor to AM, yet it isn't; it is facilitative and supportive. The need to create prototypes before the physical realization of new products is greater than ever. Prototypes are used even more than before because of more complex products, more product variations, shorter product life cycles, and the rule of ten: mistakes early in product development multiply the costs of stepping back in the process to correct them



*Courtesy of Lithoz*

by a factor of ten. As a result, developers invest significant effort in planning before mass producing a part. Simulation software and additive manufacturing both play an important role here.

An example is the use of AM to generate inner layer temperature structures for injection moulds to perfectly control temperature for higher efficiency and better quality. With AM, the mould can simply be printed directly with perfectly organized inner layer temperature pipes but simulation software is required to first calculate the optimal temperatures to be maintained, and the consequent optimal structures and positions of these inner layer pipes. Combining simulation and AM therefore enhances the availability of this tool and can increase production speed. These benefits would not be possible without using this combination of simulation and AM.

Another prominent example of this winning combination is the ability to generate a product with a grid bone structure. Previously, it was laborious and manually intensive to translate a full block of metal into such a structure; today, the ideal or optimized structure can be calculated with simulation software and then printed directly using AM.

This brings us back to the issue of skills: there is a lack of expertise in the market regarding the use of simulation tools and AM, and the skills are highly sought after. Trained AM engineers are lacking, and the

skills are diffusing too slowly within the education system because there is still too large a focus on traditional manufacturing techniques and not enough on AM techniques. This will change in time, but it is not changing far or fast enough yet.

### **Q. Are there any other challenges to be aware of?**

A. Generally, in industry, trying to print a part that has been optimized for traditional manufacturing is the wrong approach. Instead, the parts need to be ideated from scratch, starting with the customer value in mind to enable additional customer value and, in the best case, to simultaneously reduce the production effort (i.e. by consolidating the production of the various parts).

We are dealing with a bias of expertise in the market: engineering experts who know too much about traditional techniques are often not able to see new opportunities. There is also a high learning curve involved: studying this new production paradigm requires time and some trial-and-error experience, but engineers in traditional manufacturing sectors often do not have enough time for this due to the demands of their workdays.

In the short-term, I think that companies should just get started to better understand the opportunities of AM. Rather than immediately investing in a costly additive manufacturing solution, they can start training their employees in additive thinking using a low-cost machine, and they can

make greater use of specialized service providers. There is lots of knowledge stored in AM service providers that can be leveraged without a company needing to make a big investment immediately.

Comparable with cloud computing, there is an extensive network of AM service providers around the world where industrial grade machines can be accessed.

**Q. Where is more investment needed?**

A. This depends on the stakeholder perspective. There is already a very lively start-up scene and lots of research in the different areas of science.

In my opinion and as mentioned before, investment into training and education is one of the most critical areas. Furthermore, it is important to get policy makers to recognize the importance of AM for a country's industry.

For instance, if we take Austria, a highly developed and industrialized market with many SME producers that are responsible for a majority of jobs, it is very important to them to master new production technologies to remain competitive internationally and to ensure that digital manufacturing and its added value does not migrate abroad, as was the case with the majority of the internet industry. This is especially important in the digital age where new technologies are already replacing many jobs.

**Q. What do you see in the future?**

A. Europe still has the opportunity to be a major player in the AM industry because many patents and developments are already happening in Europe. Unfortunately, the continent doesn't have the same venture funding systems as the USA, nor the public initiatives of China and the Middle East.

We are also seeing more emphasis on AM post-pandemic as global distribution chains are affected by successive crises. The AM product market grew even in 2020 and 2021 and has not been impacted like other industries. I believe that the reason for this can be found in its digital and local characteristics – it provides the ability to produce flexibly and independently on site.

This is one of its big benefits: it allows governments and businesses to have multifunctional production facilities onsite that can continue to produce urgently needed parts, i.e. to keep their critical infrastructure running. We are already seeing such applications in the military sector. Since in a war situation you cannot know what will break down, and the logistics chain is often extremely complicated or even at risk, the US military is equipping its aircraft carriers with AM machines to enable it to produce whatever replacement parts are necessary wherever the carriers are and in whatever circumstances.

**Q. What about the issues of sustainability?**

A. Onsite AM production also offers sustainability advantages. AM uses energy, of course, but a massive part of CO<sub>2</sub> emissions internationally comes from the global transport of semi-assembled parts.

Moving to onsite production requires less transportation and enables you to only produce what you need as you need it. However, AM is still currently quite centralized, so the full benefits of these savings on transportation are not yet being fully realized. But we are seeing some fast-moving consumer goods (FMCG) players who are starting to leverage some of these

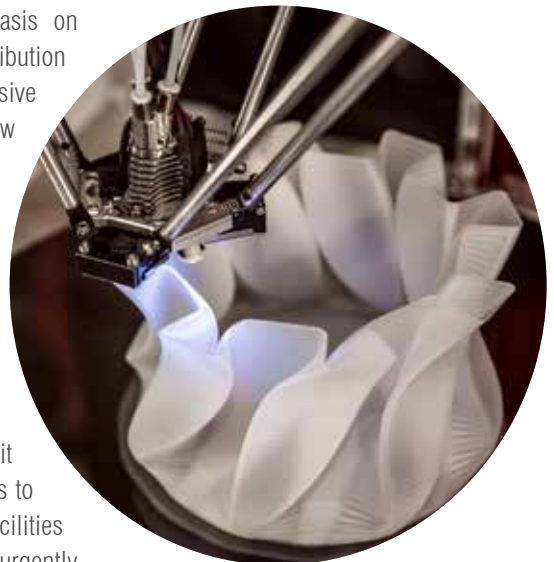

benefits, for instance when it comes to the availability of replacement parts after the end of life of products. If a company had to stock all these obsolete parts just in case, it would generate a lot of waste, not to mention the warehousing costs. Using AM, they can produce the specific replacement parts as necessary and thereby prolong the lifetime of their products.

Another aspect regarding the sustainability of AM is that its many processes only require the amount of material that goes into producing the product, unlike subtractive techniques that still generate a lot of waste. Then, as mentioned earlier, positive sustainability effects already arise from the applications themselves.

For example, the reduction of fuel/energy consumption through light-weight parts for aerospace or e-mobility applications. This has a positive effect for industry in terms of costs and also for the environment. So, used correctly, AM has major potential to be a green technology.

For more information:  
 Agnes Parfy - Additive  
 Manufacturing Austria  
[agnes.parfy@am-austria.com](mailto:agnes.parfy@am-austria.com)

## About Johannes Gartner

Dr. Johannes Gartner is Vice President of Additive Manufacturing Austria, co-founder of 3Druck.com, the leading German-language online magazine for additive manufacturing, and of 3Print.com, and he is a technology management researcher with a doctorate from Johannes Kepler University in Austria.

Article from:  
*Futurities* Year 19 n.3 Autumn 2022



# A review of the manufacturing technologies and characteristics of metal powders for additive manufacturing

by Ilaria Rampin<sup>1</sup>, Francesca Bonfanti<sup>2</sup>

1. Pometon - 2. MIMETE

## Powder production

For some time now, different technologies have been developed to produce metal powders with different shapes, sizes and chemical/physical characteristics in order to achieve the required performance for the final applications. The most widespread application for metal powders is powder metallurgy (P/M), i.e. the manufacture of components using metal powders/carbides as the main constituent, the consolidation of which is achieved through sintering.

Metal powder applications are far more numerous than what is traditionally understood by P/M. Various technologies make it possible to obtain a component with a near net shape which requires minimal subtractive operations thereby reducing material waste. Besides traditional P/M, the technologies that make the widest use of metal powders are hot isostatic pressing (HIP), metal injection moulding (MIM), and spark plasma sintering (SPS). In the list of technologies that use powders as a raw material, the large group of additive manufacturing (AM) is the youngest. While it also uses powders, the fusing mechanism is achieved by melting the powder particles and building the parts up, layer by layer.

Each additive technology requires powders with specific characteristics, making the powder manufacturing process a critical choice and, typically, only one process is used for each type of application. The technology processes for producing powders are reduction processes (e.g. electrolytic or thermochemical), mechanical processes (e.g. milling), and physical processes (atomization with water or gas). Only the latter can be used to produce powders with the necessary characteristics for AM.

Atomization refers to the breakup of a liquid into droplets and can be achieved in various ways using water, air, or inert gas. The metal is melted and then flows through an orifice where a high velocity stream of gas or liquid, usually water, hits it, breaking the molten metal into particles that solidify again very quickly.

The medium directed at the liquid metal determines the shape of the particles created: water causes a very high cooling rate that generates irregular-shaped powders suitable for P/M, while gas allows a lower cooling rate with sufficient time to obtain the spherical powders suitable for AM.

There are two main gas atomization processes: VIGA (Vacuum induction melting Inert Gas Atomization) and EIGA (Electrode induction melting Inert Gas Atomization). The VIGA process melts metals/alloys in a crucible which allows alloying and refining and produces spherically-shaped powders. This process is mainly used for nickel-based super alloys, cobalt-based alloys, ferrous metal powders (e.g. stainless steel) for additive manufacturing, and other special applications (e.g. HIP, MIM, and plasma transferred arc).

The EIGA process processes the metal or alloy in bar form without the use of a crucible and is able to produce highly spherical metal powders of extremely high purity. This production technique is mainly used for titanium alloys (as titanium is a reactive material) and it is necessary to avoid contamination. Different gases such as nitrogen, argon, air, helium, or a mixture of two gases are used for atomizing the melt metals. The choice of gas is based on economic or specific technical reasons.



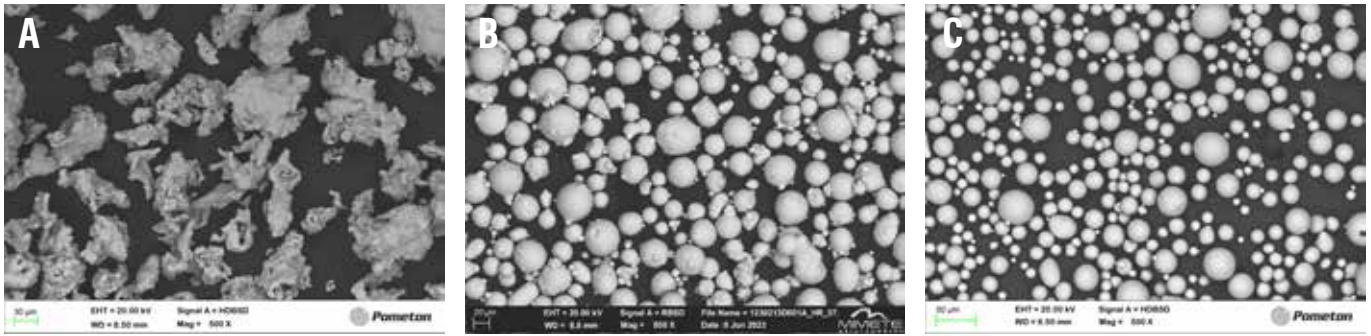

Fig. 1. Powders produced by: a) water atomisation, b) VIGA, c) EIGA.

## Powder characteristics

A metallic powder can be described according to its chemical and physical properties. The chemical analysis of a powder is often similar to that describing the traditional materials in bulk form, such as bars, sheets or forgings.

From a speculative perspective, alloys available in traditional forms can be produced in powder form, but certain restrictions apply when some of the elements are useful for traditional manufacturing but are irrelevant or harmful for additive manufacturing.

There is, however, a substantial difference in the oxygen content of powders compared to traditional forms, which is due to the surface-to-volume ratio of a powder compared to the bulk material.

The oxygen content of a powder can be 10-1,000 times higher than the content of the conventional bulk material, depending on the material, the casting method, and the powder production technique.

The oxygen content is an important characteristic of a powder because it affects the mechanical properties of the printed part and is one of the main characteristics that deteriorate with powder reuse. When an extremely clean alloy is required in order to reduce the content of undesirable trace elements (e.g. Bi, Se, Pb), the vacuum induction melting of the VIGA production technique allows these harmful elements to be removed.

The physical properties of a powder characterize its behaviour. Since the particles that make up the powder are all different, the properties can be described by a single value or by a distribution (e.g. the size).

## Measuring particle size

Powders are most commonly described by their nominal size (e.g. 15-48, 20-53, 20-60), where the 15, 20, 53 or 60 represent the nominal lower or upper "limits" of the size in micrometres. This nominal value is generally not sufficient to describe the size of the powder because the powder consists of a collection of different particles with varying diameters.

Particle size distribution (PSD) is therefore the correct description of the size. The PSD can be described as a histogram where the x-axis shows the diameter of the particles and the y-axis the number of particles of that diameter. Generally, a cumulative distribution is also associated. From the cumulative distribution, the key values of D10, D50, D90 are defined: these are the tenth, 50th, and 90th percentiles of the PSD and correspond to the particle diameters of 10%, 50% and 90% of the cumulative distribution.

There are several methods to measure the size of a powder, the most common being laser diffraction particle size distribution, and sieving. The fastest way to describe the size of a powder is through PSD via laser diffraction, a method

that allows a large number of particles to be measured. A laser interacting with the particles is diffracted and the angles and intensity of this diffraction are measured to calculate the relative PSD of the powder (see Fig. 2).

Another way to measure PSD is by sieving. A series of sieves with different mesh sizes are stacked on top of each other and the powder is fed into the top sieve which has the largest openings. Particles smaller than the sieve mesh fall through each successive sieve and the progressive reduction of the sieve mesh size allows the particles to be classified into different dimensions.

## Measuring powder density

The density of a powder can be measured by two different methods: apparent density or tap density. Apparent density is the density of the powder when it fills a given volume after passing through a funnel. It has a much lower value than the bulk density of the material because it is the average of the density of the alloy and the voids between the powder particles (see Fig. 3a). The tap density is measured after a certain quantity of powder has been tapped a specific number of times so that the finer particles fill the voids.

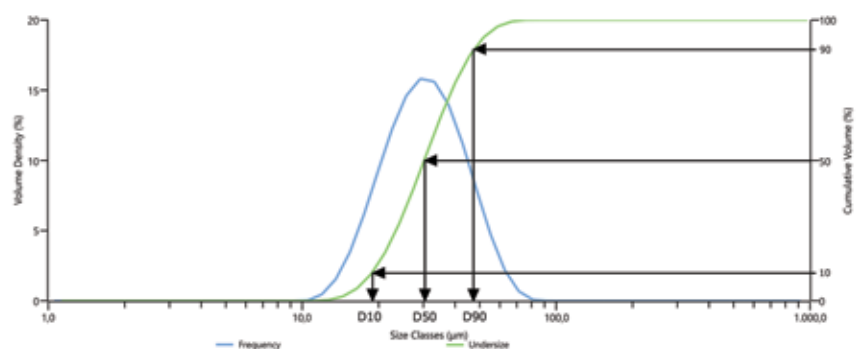

Fig. 2. An example of Particle Size Distribution (PSD) measured by laser diffraction. D10, D50, D90 are indicated on the graph.

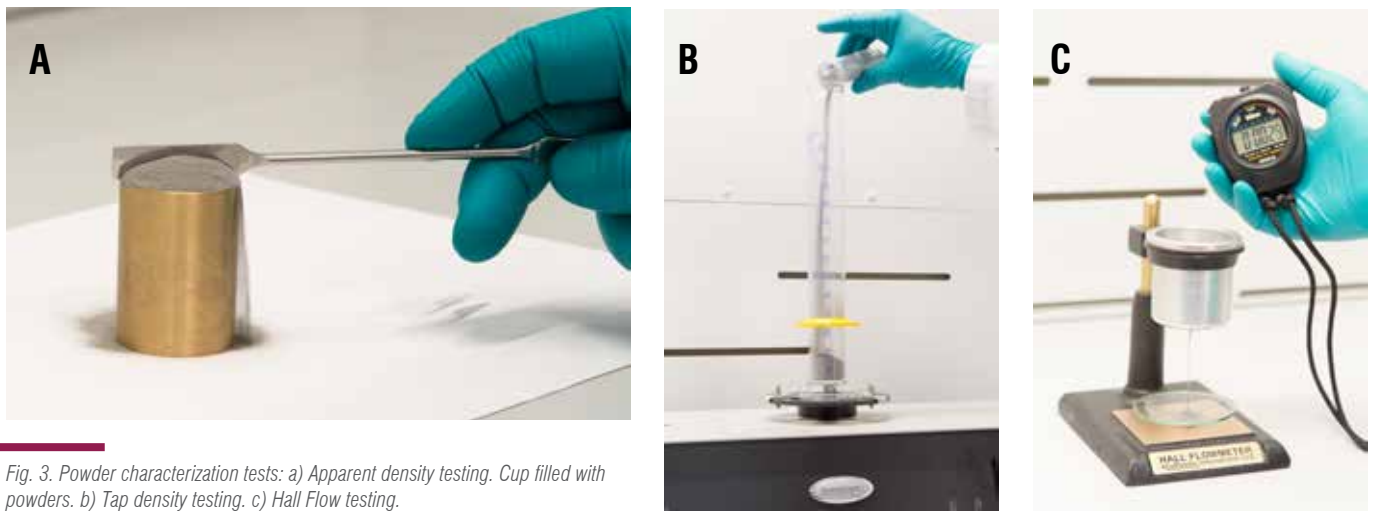

Fig. 3. Powder characterization tests: a) Apparent density testing. Cup filled with powders. b) Tap density testing. c) Hall Flow testing.

The tap density is generally higher than the apparent density and is typically used when dealing with powders in hot isostatic pressing (see Fig. 3b).

An easily measurable powder characteristic is its flowability, i.e. how many seconds it takes a powder to flow through a funnel with a calibrated hole (see Fig. 3c). This is a quick and easy test, but the result is easily influenced by test conditions and humidity, for example. While it is useful for understanding whether a powder will flow through a machine's distribution system, it does not provide any information on the quality of the powder bed or spreadability of the powder for additive manufacturing.

### Metal powder materials

Today, there is a variety of metals and alloys available in spherical form such as different grades of steel, pure copper, copper alloys, nickel-based super alloys, cobalt alloys, titanium alloys, and aluminium alloys, all of which can be and are used for additive manufacturing.

At first, manufacturers researched and used the standard chemical compositions available for other technologies, such as AISI 316L, 17-4PH, 718, AISi10, AISi7, bronze 90/10, Ti6Al4V. Over the years, the research and formulation of new materials has become increasingly important to achieve better properties and performance in order to use the technology for new and demanding applications.

Today, there are new alloys (e.g. Scalmalloy® or A20X™) that have been specially developed and registered; modifications to chemical

compositions (e.g. CuCrZr, and CuNiSiCr) have been tested; and some fully customized powders (such as Ti alloys, and special grades of steel) have been produced for specific applications. The development of powders for AM applications will continue to develop as rapidly as the advancements in AM manufacturing.

For more information:  
 Ilaria Rampin - Pometon  
[ilaria.rampin@pometon.com](mailto:ilaria.rampin@pometon.com)  
 Francesca Bonfanti - MIMETE  
[francesca.bonfanti@mimete.com](mailto:francesca.bonfanti@mimete.com)

## About Pometon

Founded in 1940, Pometon is today the largest European producer of copper powder and offers a unique service to its clients producing also ferrous, non-ferrous powders and stainless-steel shot. Pometon produces pure powders such as iron, copper (both electrolytic and atomized), bronze, brass, tin, zinc, press-ready iron and bronze premixes. Its division, Pometon Plus is fully dedicated to the production of spherical metallic powders for 3D printing using VIGA & EIGA technology, and can produce customised powders in Copper, Stainless Steel, Cobalt-Chromium, Nickel-Chromium Titanium and Alloys. Based in Maerne, Venice, Pometon has subsidiaries in UK, Spain, Germany, India, Türkiye, Korea and a second production site in Serbia, cooperates with the major automotive brands and the renowned global players in the chemical industry, aerospace and electronics sectors. Equipped with latest technology, the R&D Centre collaborates with the most important worldwide universities with the objective of producing customized powders to meet individual customer requirements and to ensure that product quality remains consistent over time.

## About MIMETE

MIMETE specializes in producing gas-atomized powders in iron, nickel, and cobalt-based alloys. Founded in 2017 and based in Biassono in the province of Monza and Brianza, near Milan in Italy, MIMETE is part of the FOMAS Group, an international organization that has been manufacturing open-die forgings and seamless rolled rings since 1956. The group's core strength is the expertise and know-how it has acquired over 65 years in the science of metals. Today MIMETE offers three lines of powders, listed by different grades and PSD ranges and suitable for applications such as AM, HIP, coating and MIM. The powders are used in the power generation, oil&gas, aerospace, biomedical, automotive and general industry sectors. The whole group is driven by a high-performance culture that focuses on valuing others, inspiring innovation and growing responsibly.

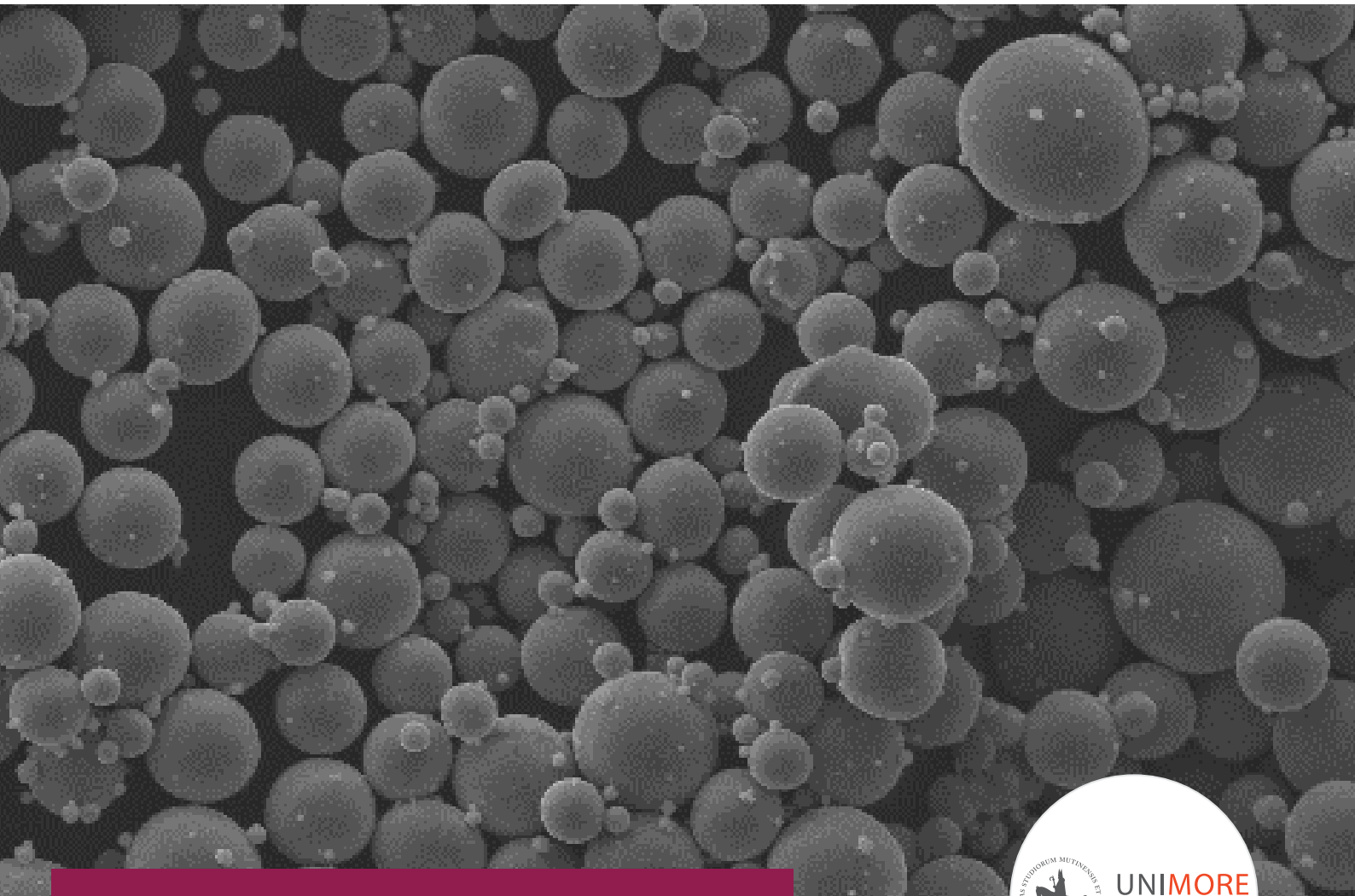

# The importance of knowing metal powders' properties and process effects in additive manufacturing

by **Paolo Veronesi, Elena Colombini, Magdalena Gualtieri**

"Enzo Ferrari" Department of Engineering, University of Modena and Reggio Emilia, Italy

Metal Additive Manufacturing (MAM) is rapidly transforming the way metal parts can be manufactured and many industries are currently taking advantage of the multitude of untapped opportunities it offers. However, there are many challenges imminent to ensure the success of this technology in a wider range of applications.

Among them, the link between the manufacturing process parameters and the material properties poses new challenges compared to more traditional metal forming processes and also compared to powder moulding and sintering processes. Quality management systems therefore require inspection and verification, starting with the metal powders to be used in the process.

Over the years and due to the rapid advent of MAM, many companies have created their own internal standards regarding materials or processing guidelines, mainly due to the lack of internationally accepted technical standards. Nowadays, the situation has changed and new standards are being released or updated, covering terminology, processes, and materials or classes of materials. For instance, the "ISO/ASTM 52907:2019 — Additive manufacturing — Feedstock materials — Methods to characterize metal powders" deals with some relevant aspects of metal powders, which will soon be addressed in this paper, namely particle size distribution, chemical composition, density, morphology and flow characteristics. It also addresses the problems of powder contamination and provides specific

requirements for metal powders used in additive manufacturing.

## The standard prescribes requirements for:

### Sampling

The main requirement is that the sample be representative of the powder batch. Indeed, after powder production, storage and transportation can lead to the segregation of powders. This phenomenon is particularly evident in the case of powders with a wide particle size distribution. The sampling method should agree with the batches, possibly referring to existing standards, such as ISO 3954.

### Particle size distribution

Microscopy, sieving, light scattering, and diffraction are suitable techniques for determining particle size. One of the main assumptions of most of these measurement techniques is that particles are spherical, and that their diameter can be taken as a parameter to describe particle size. Despite the widespread use in MAM of gas-atomized particles with a regular, almost spherical shape, particles with different morphology are commonly found on the market. Therefore, neglecting the analysis of particle shape together with particle size distribution can lead to errors; moreover, in the case of non-spherical particles, the comparison between these techniques becomes difficult.

For the quantitative comparison of the particle size distribution between two different powders, the widths of the distributions are usually used. From the cumulative size distribution, it is possible to derive  $D_{10}$ ,  $D_{50}$  and  $D_{90}$ , i.e. the first, middle or last decile, respectively. The most commonly used techniques for determining particle size distribution are as follows:

- Microscopy with image analysis – allows simultaneous determination of particle size distribution and particle shape; the powders must not be in contact, so liquid suspensions can also be used; if used on moving particles, a larger number of observations can be made thus

expanding the data available for statistical analysis. Datasets of at least 3,000 particles are recommended [1];

- Sieving – uses stacked sieves of different mesh size, and the amount of powder remaining between the sieves is measured. It is the least expensive method but usually works on particles larger than 45µm and provides a gradual distribution of particle size. It is strongly influenced by the sieving time and possible wear or contamination of the sieves. Furthermore, it assumes that the particles are spherical, ignoring the fact that elongated powder particles may pass through the meshes of the sieves despite having a larger size than the mesh;
- Light scattering – measures the speed of particles within a distribution of particles subject to a Brownian motion, with smaller particles moving at higher speeds than larger ones. Light from a monochromatic source is scattered when it interacts with the suspended particles and is detected at a certain angle in time, and this signal is used to determine the scattering coefficient and particle size using the Stokes-Einstein equation. Together with diffraction techniques, it provides the most accurate results while requiring a limited amount of powder. However, the technique assumes that the particles are spherical and do not touch each other;
- Laser diffraction – detects and analyses the angular distribution of the resulting scattered light when the laser beam passes through a scattering of particles in air (dry method) or liquid (wet method). The intensity and angle of scattered light depends on the particle size. This technique applies to particles of a slightly larger size than those typically measured by light scattering, i.e. 0.1µm–3mm. The same assumptions and requirements apply. The laser technique offers better resolution, but tends to overestimate the particle

size distribution compared to sieving or direct observation.

### Chemical composition

Different standards exist suggesting the use of atomic absorption spectrometry, flame emission spectrometry, X-ray fluorescence, or wet chemical methods. Particular care must also be taken in the determination of interstitial elements or contaminants, such as hydrogen, carbon, nitrogen, and oxygen, which tend to increase as the number of powder reuses increases.

### Characteristic density

Density, generally defined as mass/volume ratio, can be measured according to different standards that consider the way the sample is prepared and how it is tested:

- Apparent density is the ratio of the mass of the powder to the volume occupied by the powder, including the voids between particles. It represents the packing of a free-flowing powder when measured according to ISO 3923-1;
- Tap density is the ratio of the powder mass to the volume occupied by the powder after it has been poured a defined number of times. It is the apparent density obtained under standard tapping conditions. It provides a representation of a random dense packing of the powder;
- True or skeletal density measures the density of the material of which the powders are made, without pores. Therefore, compared to the previous values, it can also provide an indication of porosity.

### Morphology

This term describes the shape of powders and is relevant for MAM considering that spherical particles can organize and pack themselves more efficiently than particles with irregular morphology for example by presenting satellites.

Microscopy is the suggested method for determining the morphology of MAM powders and when using scanning electron microscopy, a secondary electron detector must be used.



## Why so much interest in powders properties?

When dealing with powders, any Ishikawa chart for the L-PBF MAM process inevitably mentions the effects of powder chemistry, morphology, and flowability, or the possibility of generating layers with desired and reproducible properties.

Furthermore, these properties influence the thermal properties of the layer and its ability to interact with the laser beam. Therefore, proper powder quality control is mandatory for MAM, and becomes even more relevant when introducing used powders.

Typically, the particle size distribution of used powders differs from that of virgin powders, with the finer fraction decreasing.

In addition, some absorption of moisture or interstitial elements may occur

during repeated processing, with some uncontrollable effects on the achievable density and mechanical properties.

Therefore, even when simulating a MAM process, the properties of the feedstock used must be correctly implemented in the model, possibly considering the evolution of virgin and used-powder mixtures.

For more information:

Paolo Veronesi - Università degli Studi di Modena e Reggio Emilia  
paolo.veronesi@unimore.it

## References

- [1] P. R. Samal, and J. W. Newkirk (eds), *ASM Handbook, Volume 7: Powder Metallurgy*, ASM International, 2015, <https://doi.org/10.31399/asm.hb.v07.9781627081757>
- [2] J. Zegzulka, D. Gelnar, L. Jezerska, R. Prokes, and J. Rozbroj, "Characterization and flowability methods for metal powders", *Scientific Reports*, 10, 21004 (2020), pp. 239–245, <https://doi.org/10.1038/s41598-020-77974-3>
- [3] S. Gorsse, C. Hutchinson, M. Gouné and R. Banerjee, "Additive manufacturing of metals: a brief review of the characteristic microstructures and properties of steels, Ti-6Al-4V and high-entropy alloys", *Science and Technology of Advanced Materials*, 18:1 (2017), pp. 584–610, <https://doi.org/10.1080/14686996.2017.1361305>
- [4] J. J. Lewandowski, and M. Seifi, "Metal Additive Manufacturing: A Review of Mechanical Properties", *Annual Review of Materials Research*, 46 (July 2016), pp. 151–186, <https://doi.org/10.1146/annurev-matsci-070115-032024>
- [5] W. H. Kan, L. N. S. Chiu, C. V. S. Lim et al, "A critical review on the effects of process-induced porosity on the mechanical properties of alloys fabricated by laser powder bed fusion", *J Mater Sci* 57 (2022), pp. 9818–9865, <https://doi.org/10.1007/s10853-022-06990-7>

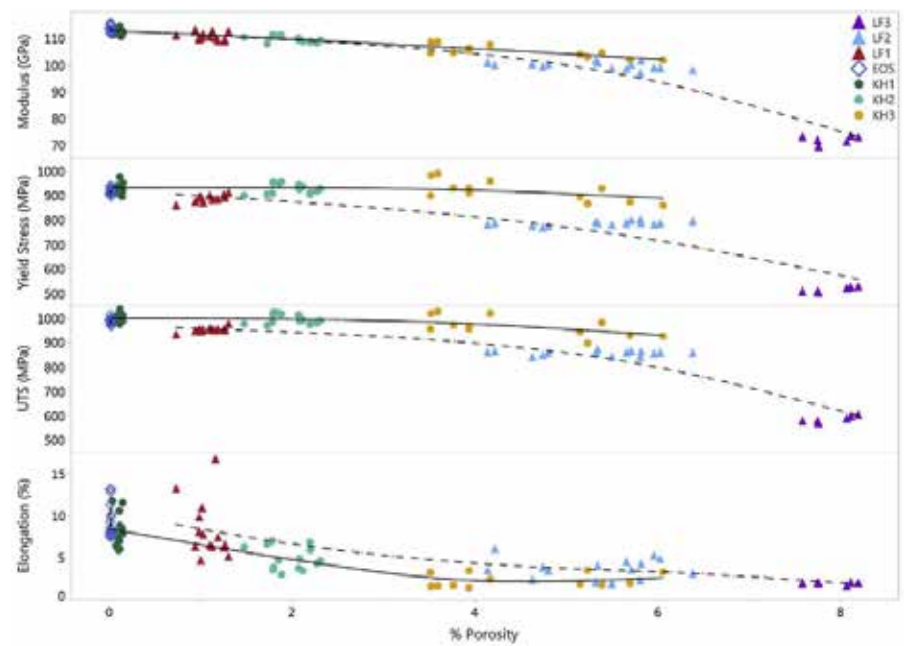

Fig. 3. Effect of porosity on the mechanical properties of L-PBF Ti6Al4V produced using different processing parameters to generate defects: LF=lack of fusion (dotted line); KH=keyhole (solid line); EOS= standard EOS processing parameters for a Ti-6Al-4V alloy [5].

## About the “Enzo Ferrari” Department of Engineering

Established more than 30 years ago, the Italian University of Modena and Reggio Emilia's "Enzo Ferrari" Department of Engineering was founded in the academic year of 1990-91. Its main building, which covers more than 160,000m<sup>2</sup>, meets the highest teaching and research requirements. The department regularly collaborates with renowned firms in the car manufacturing, chemical, mechanical, ceramics, and biomedical fields, as well as enterprises in the information technology, telecommunications, and industrial electronics sectors. Over the years, this network has helped the department to further develop and improve the high quality of its research and its technological application.

The department's DIMANT (Design of Innovative MAterials for New Technologies) group has been active since the very beginning with the aim of creating a synergy between teaching and research by pursuing excellence in the former and efficacy in the latter. Today, more than 20 permanent researchers and professors call DIMANT their professional home, along with an equal number of non-permanent researchers. The group brings together experts and expertise in the field of materials science and engineering, including polymers, ceramics, metals, composites, and biomaterials and their processing. It also concerns itself with the synthesis and transformation of materials for sustainable technologies, and with the interactions between materials and the environment, including tribology and wear. For further information, visit: [www.unimore.it](http://www.unimore.it)



# L-PBF additive manufacturing simulation of a “cold crucible” in copper alloy

by Nicola Gramegna<sup>1</sup>, Antonio Rossi<sup>2</sup>

1. EnginSoft - 2. AddtoShape

## Introduction

The TEMART project was approved by Italy's Veneto Region under the POR-FESR 2014-2020 program under Axis 1 and Action 1.1.4, namely "Support for collaborative R&D activities for the development of new sustainable technologies, new products and services".

The four Regional Innovative Networks (or Reti Innovativi Regionali – RIRs) that participated in the TEMART project, namely M3NERT, EUTEKNOS, VHC and VSL, operate in three different areas of Smart Specialization representing some of the most significant and distinctive domains and industrial sectors in the industry and artisanship of the Veneto region. The region's four universities, coordinated by the Univeneto Foundation, also participated in the project as partners, making complementary contributions that reflect the specific character of their research and training specializations. As a result, the TEMART project has become highly significant industrially, economically, socially, and culturally. The project involved the development of several

case studies concerning the creative use of technologies and processes to produce innovative, competitive, aesthetically pleasing, high quality items. New manufacturing technologies, in particular additive manufacturing (AM) technologies, make it possible to design and produce new shapes with a broad range of materials e.g. polymers, composites, or metallics and even to combine these in the same item/object. As an example, one of the project goals was to integrate different CAE tools into a single intelligent design process for the AM environment. This integration created competitive advantages such as reduced design times with the maximum reduction, for example, in weight and a maximum increase in the part's functional reliability. With regard to the specific project areas, the case study on crucibles made of refractory metal was a prime example of the reduction in weight and increase in functionality.

After a brief introduction about the implementation objectives of the “cold crucible”, this article describes the virtual approach adopted to design the component and optimize the manufacturing

process for CuCr1Zr copper alloy. The partners listed in the acknowledgments played a key role in characterizing the material and fine-tuning the machine parameters for manufacturing the part, which helped confirm the excellent design, and the modelling of the AM process.

## Objectives

Officina dei Materiali, a consulting company in the field of materials science and engineering, first launched the idea of next-generation cold crucibles in 2015. The idea quickly gained momentum thanks to the first funded projects which aimed to use simulation software to model the physical phenomena at play during levitative metal melting, and to optimize the technological process of additive manufacturing with pure copper.

The main objective of this study is to demonstrate how additive technologies combined with simulation methods can enable continuous progress in the creation of innovative and efficient products.

The component being studied is a crucible for the controlled melting of metal. Conventional crucibles are usually made of ceramic material with the obvious limitations of high cost relative to service life, and the contamination of the molten metal by the ceramic material itself. Such contamination affects and sometimes impairs the mechanical, electrical, and magnetic properties of many reactive metal alloys.

A “cold crucible”, on the other hand, is made of a metal alloy with high thermal and electrical conductivity. This crucible, when suitably cooled and designed, can concentrate its electromagnetic energy to melt the metal contained in the crucible. It does not contaminate the melt in the crucible and also, conceptually, does not use consumables because, if properly designed, it never comes into contact with the molten metal.

Some prototypes demonstrated the cold crucible's potential, but also its limitations compared to production using traditional

manufacturing technologies. Furthermore, during validation, some operating efficiency limitations emerged regarding the transfer of electromagnetic energy internally, and heat dissipation.

Using additive technologies enables radically new shapes and geometries to be created. L-PBF (laser powder bed fusion) technology is probably the most versatile of the additive technologies for metal parts in terms of its potential to produce complex geometries in combination with ad-hoc microstructures [1]. More specifically, such technologies can enable the production of more thermally and electromagnetically efficient parts by realizing complex geometries and designing appropriate channels for controlled conformal cooling.

The aspects to consider in producing an object that meets the design specifications as studied and confirmed through the use of additive manufacturing process simulations include optimized complex internal channels, thin walls, and thickness transitions.

## Part design for additive processing

In recent years, simulation tools have continuously evolved to support design, or more specifically to complete the virtual workflow of Design for Additive Manufacturing (DfAM), in order to drastically reduce the number of iterative experimental tests, which are very costly and time-consuming. However, there continue to be well-known challenges not least of which are the simulation methods used and the associated computational times. Some of these have been highlighted in the literature by various authors [3]. The main sources of complexity relate to the numerous physical phenomena involved, some of which are difficult to model; the spatial and temporal discretization; and finally, the experimental validation of the results.

This study aims to simulate the L-PBF additive manufacturing process at a macro scale with the goal of determining the residual stresses, distortions and defects related directly to the process itself. The macro-scale simulation uses continuous models in which the material layers are merged into layers of finite elements,

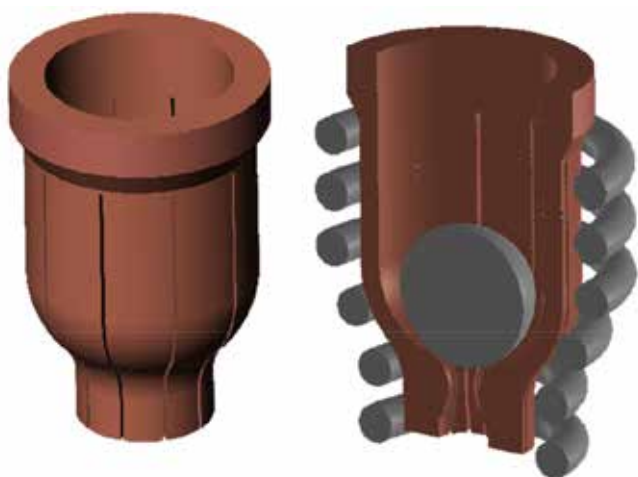

Fig. 1. View of the crucible (courtesy of Officina dei Materiali).

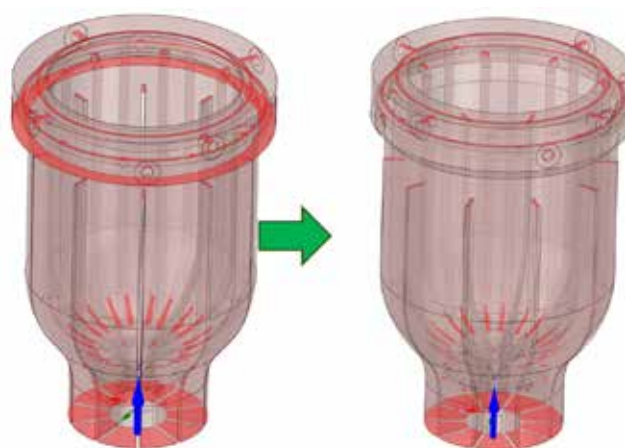

Fig. 2. Geometric analysis of the CAD in terms of a 45° overhang angle relative to the direction of material growth (Z-axis print direction).



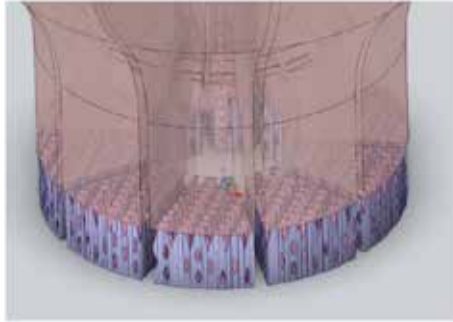
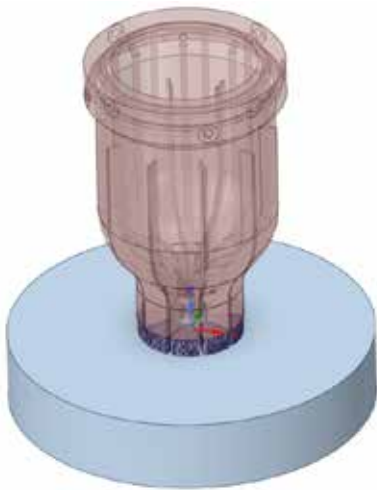

Fig. 3. Support structures built with Ansys Additive Prep for process simulation.

thereby partially foregoing resolution on actual thermal gradients and micro-scale phenomena. Rather than progressively adding material along the laser path, an entire layer is deposited. This only requires the specification of the direction of material accretion and the height of the simulated layer, which greatly reduces the complexity of the simulation setup.

The design of the part required several steps leading up to the analysis of the geometric models in terms of printability by using an analysis of the regions that require supporting structures and that are potentially critical to realize. In Fig. 2, those areas with an “overhang angle” greater than  $45^\circ$  (in red) that require support are highlighted and minimized.

Fig. 3 shows the print setup with the supporting structures that connect the part to the platform.

### Simulation of the L-PBF manufacturing process

Similar to conventional welding simulation, the inherent strain approach provides a computationally efficient method to simulate the production of complex metal additive parts on a macroscopic scale. The aim is to predict residual stresses and distortions in the part. This approach simulates a build-up of thermal stress by activating the macro-layers sequentially and applying inherent strain.

Inherent strain is a permanent plastic deformation of the material that subsists

in the Heat Affected Zone (HAZ) of the weld, and it is this region which causes the overall deformations and residual stresses.

As this region is an accumulation of various physical phenomena, it is necessary to use a calibration procedure to determine the average total inherent strain, which is only valid for a specific machine model, material and set of process parameters. The accuracy of the material model therefore hinges directly upon the calibration. Such simulations can be conducted with the bare minimum of material property information, that being the mechanical properties at room temperature.

### Calibration of the material model

Cantilever beam specimens are now standard for determining inherent strain value as the distortion measurements are simple. Once the test specimens were printed (using the same setup as for the manufacture of the object), they were partially cut from the manufacturing platform near the base, leaving intact the thicker section of the cantilever beam connecting it to the platform. The distortion was measured at three positions (M1, M2, M3) before and after cutting, and the average value was used for the calibration procedure (Figs. 4 and 5).

Essentially, the goal is to identify the calibration parameter (Strain Scaling Factor, or SFF) of the intrinsic strain which matches the measured experimental distortion with the virtual distortion of the simulation.

### Process simulation setup

Despite the fact that intrinsic strain values are anisotropic according to the direction of the scanning vectors in relation to the scanning strategy, which is caused by a greater contraction along the scanning direction rather than orthogonally to it,

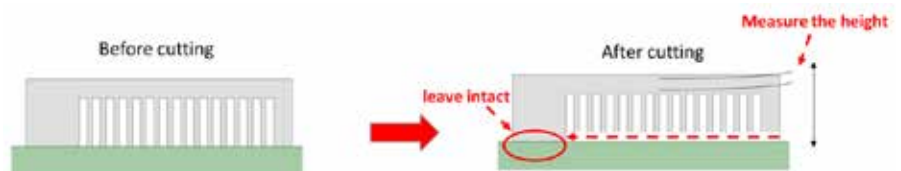

Fig. 4. Calibration procedure.



Fig. 5. SLM additive manufacturing specimens for calibration (courtesy of ECOR).

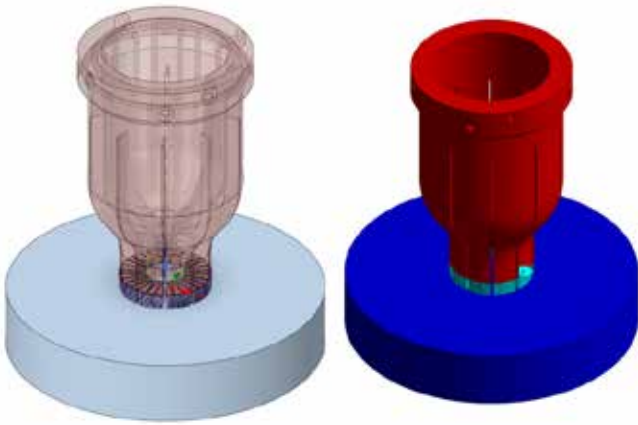

Fig. 6. Setup for manufacturing, and setup in Ansys for LPBF additive process simulation.

they are essentially isotropic when the different powder layers are averaged into a finite element layer that incorporates  $n$  layers of material (macro-scale approach). The crucible was discretized with tetrahedral FEM (finite element method) elements measuring 0.5mm, which provide a good representation of the geometric features, especially for the cooling channels.

The non-linear material used for the calibration procedure was also used to simulate the part (job).

### Simulation results

This article describes the important results of the manufacturing configuration considered optimal for manufacturing the CuCr1Zr copper alloy crucible.

The following images of the simulation results show the distributions of distortions induced by the manufacturing process, layer by layer until the end of the process. The thermo-mechanical equilibrium induces a state of residual tension and deformation of the part attached to the base platform by the supports (Figs. 7a and 8a). The same observations, using cross-sectional or external surface views, are made following the detachment of the part from the platform and the removal of the supports (Figs. 7b and 8b).

Preliminary analysis of the results shows that in the as-built condition, i.e. still anchored to the platform, the part is not subject to such distortion as to impair its operational functionality. However, when analysing the distortions after the post-processing steps of

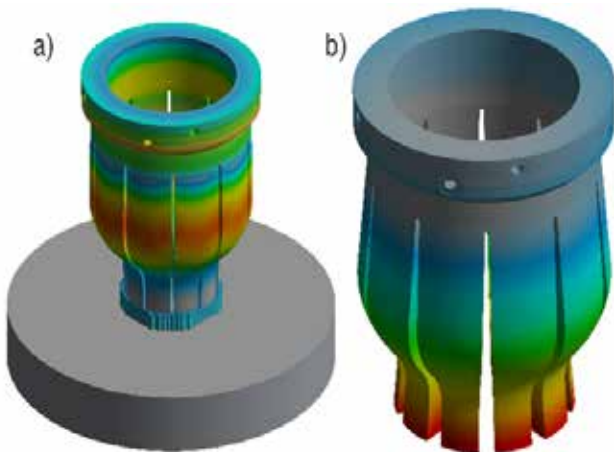

Fig. 7. Part distortions in as-built conditions after process simulation. (Left) Job anchored to platform. (Right) After detachment from platform and removal of supports.

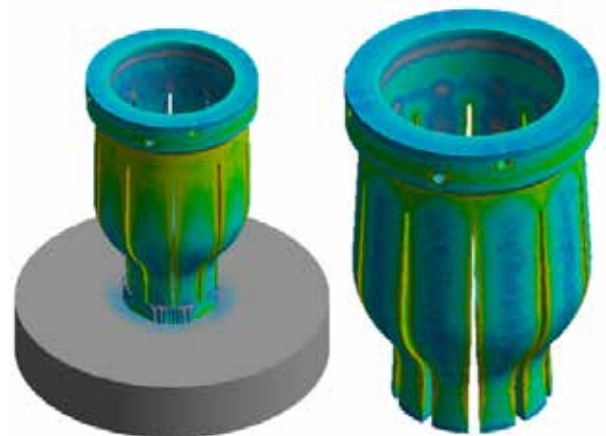

Fig. 9. Stress on the part in the as-built condition after process simulation (Right) Job anchored to the platform. (Left) After detachment of the part from the platform and the removal of supports.

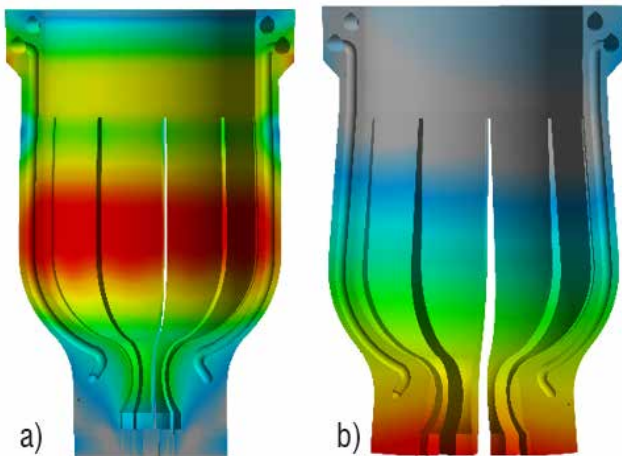

Fig. 8. Cross-sectional view of part distortions in as-built conditions after process simulation (Left) Job anchored to platform. (Right) After detachment from platform and removal of supports.



Fig. 10. Cross-sectional view of the stresses on the part in the as-built condition after process simulation (Left) Job anchored to the platform. (Right) After detachment of the part from the platform and removal of supports.

removing the part from the platform and removing its supporting structures, a substantial increase in distortion can be seen. This indicates that heat treatment to relieve residual stresses and avoid subsequent distortions is necessary to obtain a component that deviates as little as possible from the nominal geometry.

The maximum value in terms of residual stresses exceeds the fracture stress but is limited to very narrow areas and is due to the peculiarities of certain mesh nodes. Further investigation is needed to verify the above observations.

### Remarks and conclusions

The TEMART project's intended objectives were successfully achieved in this industrial case where the virtual approach to the design of the copper alloy crucible made it possible to produce the object successfully at the first attempt (right first time). The first prototype's material density and final shape matched expectations.

By designing the component according to DfAM (Design for Additive Manufacturing), the geometry was studied from the perspective of the production process, allowing us to identify the potential critical areas during the design phase even before producing the part, and therefore determine how to modify them. The process simulation made it possible to predict tension and deformation values in order to assess the component's compliance with the design specifications and to take countermeasures in the event of non-conformity thus eliminating the iterative process in the field.

Upon completion of the project in early 2021, the first example of a new-generation cold crucible designed to melt metals and metal alloys with a high melting point was produced and tested. Internally, the shape of the funnel and the number of cuts were optimized to produce a gradual variation in levitating force (in order to accommodate alloys of different densities) while retaining a conveniently sized nozzle for tapping melt that can be controlled electromagnetically; the production by additive manufacturing adhered faithfully to the optimized complex shape.

Apart from numerous advantages over traditional crucibles, the new crucible demonstrated a considerable energy-saving capability, reducing the power consumption required to melt metals by a factor of 3-4 compared to traditional cold crucibles.

Addtoshape was created in 2022 from a meeting between Seitron, an industrial production company that has operated on Italian and foreign markets for over 40 years, and Officina dei Materiali.

Addtoshape was established on the foundations of Seitron's strong spirit of innovation and modern industrial production capacity, Officina dei Materiali's decades of experience in national research facilities, and a registered patent (no. 102021000024227 (filing date 21/09/2021)) protecting the new-generation crucible. Seitron, ever attentive to the evolution of technologies and to the

challenges posed by new processes and new markets, has decided to take on the adventure offered by additive metal manufacturing of pure copper, in order to support the production of new-generation cold crucibles.

### Acknowledgements

We would like to thank the M3NET Consortium, project leader of the TEMART ("Tecnologie e materiali per la manifattura artistica, i beni culturali, l'arredo, il decoro architettonico e urbano e il design del futuro" or technologies and materials for artistic manufacturing, cultural heritage, interior design, architectural and urban decoration, and the design of the future) project and all the project partners – with particular reference to Officina dei Materiali, Ecor International, and the Department of Industrial Engineering (DII) of the University of Padua.

For more information:

Antonio Rossi – Addtoshape  
antonio.rossi@addtoshape.com

Article from:

*Futurities* Year 20 n.2 Summer 2023

### References

- [1] C. Meier, R. W. Penny, Y. Zou, J. S. Gibbs, and A. J. Hart, "Thermophysical Phenomena in Metal Additive Manufacturing by Selective Laser Melting: Fundamentals, Modeling, Simulation, and Experimentation", *Annual Review of Heat Transfer*, vol. 20, no. 1, pp. 241–316, 2018.
- [2] BSI Standards Publication, BS EN ISO / ASTM 52911-1:2019 *Additive manufacturing - Design Part 1: Laser-based powder bed fusion of metals*, October 2019.
- [3] W. J. Sames, F. A. List, S. Pannala, R. R. Dehoff, and S. S. Babu, "The metallurgy and processing science of metal additive manufacturing", *International Materials Review*, vol. 61, no. 5, pp. 315–360, 2016.
- [4] L. Bertini, F. Bucchi, F. Frendo, M. Moda, and B. D. Monelli, "Residual stress prediction in selective laser melting: A critical review of simulation strategies", *The International Journal of Advanced Manufacturing Technology*, vol. 105, no. 1–4, pp. 609–636, Nov. 2019.

## About Addtoshape

Addtoshape designs and manufactures, through additive manufacturing, innovative windings in pure copper for high performance electric motors. Complex geometries, otherwise not achievable with traditional, round or flat copper wire, are now achievable without limits, allowing maximum freedom of expression in terms of shape, function and performance. Despite large-scale production capacities and high efficiency achieved by traditional windings, the growing pressure from environmental policies is pushing the electric motor sector to a leading role in the fight to reduce global greenhouse gases. To achieve this, it is necessary to reduce the carbon footprint of electric motors by further increasing their efficiency and power density.



Fig. 1. RENAULT F1 Team Race Car.

## Optimization of the SLM/DMLS process to manufacture an aerodynamic Formula 1 part

by N. Gramegna<sup>1</sup>, D. Boscolo<sup>1</sup>, P. Veronesi<sup>2</sup>, M.F. Bolinauri<sup>2</sup>, F. Baiocchi<sup>3</sup>, N. Forghieri<sup>3</sup>

1. EnginSoft - 2. Università degli Studi di Modena e Reggio Emilia - 3. ADDITIVA

Metal additive manufacturing (AM) is widely used in Formula One, motorsport and racing to manufacture complex parts in a short time. Power Bed Fusion (PBF) technologies, such as selective laser melting (SLM) and direct metal laser sintering (DMLS), are currently used to manufacture parts (e.g. exhaust systems, aerodynamic inserts and wings, pipes, roll hoops, etc.) in aluminium, titanium, Inconel and other high-performance super alloys [1,2]. The main success factors driving the increased use of metal AM in motorsport are the maximum freedom assured during the design phase; and the possibilities of manufacturing lightweight parts, using complex geometries, and using lattice structures with controlled variable densities. Nevertheless, metal AM is not synonymous with perfection; it too has limits and constraints. One of its critical issues is the distortions that occur to the part during the laser melting process. It happens particularly with thin-walled titanium components, which frequently deviate from the nominal 3D CAD geometry despite stress-relieving treatments. The use of simulation tools to limit and compensate for the distortions can dramatically reduce the risk of scraps and delays in delivery, and the related costs. This paper presents the RENAULT F1 Team's AM process for an aerodynamic insert in Ti6Al4V titanium. Production was optimized by identifying the best orientation for the parts and the best positioning for the support structures in the melting chamber, in addition to using the Ansys Additive Print module, a simulation software useful for predicting the distortion of a part and for developing a new, 3D, compensated model that guarantees the best "as-built" quality.

Metal additive manufacturing (AM) is one of the enabling technologies of Industry 4.0. It differs from conventional manufacturing processes (e.g. machining, forging, casting, etc.) in that three-dimensional parts are produced by adding material layer by layer.

Metal AM has several advantages over conventional manufacturing processes:

- maximum weight reduction (by "putting the material just where it is required")
- maximum freedom in design (complex geometries, lattice structures, variable density control)
- highest levels of part customization
- no tooling or other production equipment costs
- reduced time from design to functional part
- simplification of the bill of materials since a subassembly of different parts that are welded together is replaced by a single AM monolithic part (zero leakage, and reduced assembly and inspection costs)

- ability to develop new materials and previously non-existent microstructures
- ability to replace worn out or broken parts that are either out of production or out of stock

Power Bed Fusion (PBF) technologies, such as selective laser melting (SLM) and direct metal laser sintering (DMLS), are currently used to manufacture parts (e.g. exhaust systems, aerodynamic inserts and wings, pipes, roll hoops, etc.) in aluminium, titanium, Inconel and other high-performance alloys [1,2]. As a result of the wide range of parameters and variables in the SLM/DMLS processes, there are often several ways to print the same part, each with different manufacturing times, costs and quality levels. Moreover, the current limitation of 3D printing renders some 3D models more expensive, or even unfeasible, by AM.

The most critical limits and constraints of metal AM are:

- low productivity (limited mass per hour melted by the lasers)
- the high cost of 3D printing machines and the metal powders
- the need to provide support structures (to prevent the first layer of molten metal collapsing on the powder bed)
- distortions occurring during the melting process

It is, therefore, useful to fine-tune the 3D model of the part to reduce the AM cost, achieve a better trade-off between quality and cost, and ensure the realization of a suitable part by AM. The Design for Additive Manufacturing (DfAM) guidelines support designers in

	Z axis height [mm]	Printing time [hrs]	Simulation time [h]	Max Displacement [mm]	Level of distortion	Internal support volume [mm <sup>3</sup> ]	Workload for support removal
1	88	8:30	3	0.96	high	803	++
2	58	5:50	2	2.50	high	863	+
3	19	3:00	1	0.28	low	1868	++++
4	107	9:30	4	0.74	low	331	++

Table 1 - Results of part orientation screening.

achieving this objective, enabling them to understand the real strengths and weakness of the technology in order to maximize the first and limit the second.

One aspect addressed by DfAM concerns the simulation of laser melting to predict and correct the distortions that can occur in parts during melting.

The high energy density and, most importantly, the rapid solidification causes residual stress the intensity of which is dependant upon: the building strategy; the part's orientation in the melting chamber; the presence/absence of support structures; the geometry, density, mass and distribution of the supports; and the thermal conditions. Residual stress induces distortions in the as-built part, even before the supports are removed, resulting in differences between the nominal dimensions of the 3D CAD model and the real shape and dimensions of the AM part. Manufacturers usually manage this critical issue with a "trial-and-error method", or by taking decisions based on their own experience. However, if they are not correctly engineered, parts can be out of tolerance at the end of the process, meaning they have to be discarded, resulting in higher

costs and longer delivery times. As a result, the prediction of and compensation for distortions are fundamental objectives.

Knowledge of material properties is essential to understanding how the powder changes in the melt pool and how it creates the part, layer by layer. The first aspect occurs at a microscopic scale, while the latter occurs at a much larger scale. Hence, a multi-scale approach is required to predict the possible results of the AM process.

Modern CAE simulation tools offer new opportunities to add value and diversify a company's services in this area by providing the ability to re-design the product from the beginning using advanced simulation tools that can accompany the entire product development process. Once the shape of the part has been defined, the designer and the manufacturer can shift their focus to the AM production process, in order to predict possible defects or non-conformities, and to better manage the parameters of the 3D printers. Simulation plays a decisive role thanks to modern techniques that can virtually reproduce the printing phase, analysing the complex multi-scale and multi-physical (thermo-structural) phenomena in a transitory manner.

This phase becomes even more appealing when performed via a direct interface between the 3D printers and the simulation software, allowing the file in the print format to be read and the metallurgical quality (porosity, residual stress, anisotropy, etc.) of the material to be forecast.

### F1 wing challenges

The main factors driving the increased use of metal AM in motorsport and racing are weight reduction; maximum design freedom; the use of high-performance materials; and short lead

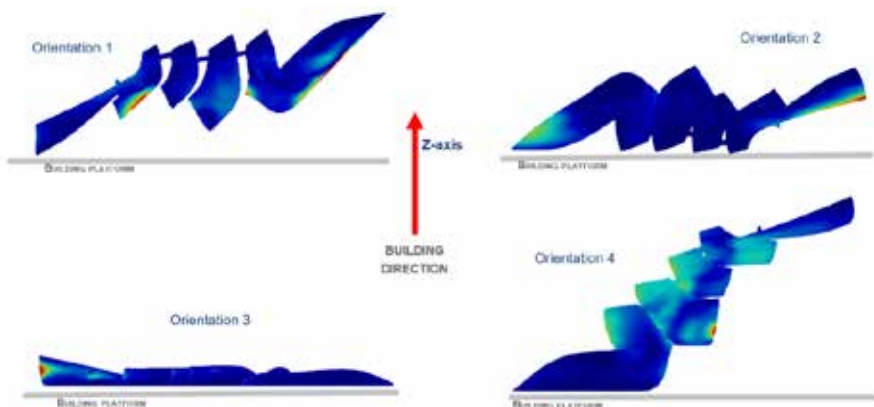

Fig. 2. Comparison of different orientations.

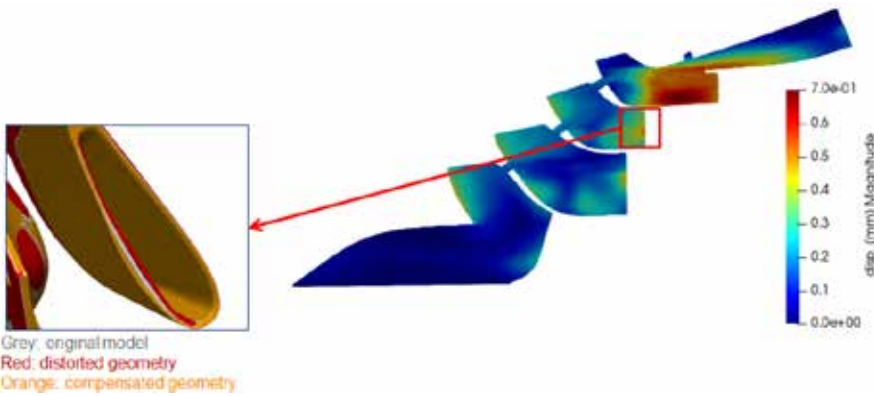

Fig. 3. Simulation results: (right) simulated distortion in printing orientation 4 and (left) automatic compensated geometry generation.

	component	supports	contour
laser power [W]	370	170	220
scanning speed [mm/s]	1250	1300	1750
spot size [um]	150	100	70
hatch distance [mm]	0.16	-	-



Fig. 4. Printing parameters and final 3D printed wing (compensated geometry).

times. One of the most important uses for AM in Formula 1 concerns aerodynamic inserts and wings with their complex geometries, internal cavities, and thin walls. Thanks to its strength and stiffness, Ti6Al4V Titanium is the best material to use for heavily loaded aerodynamic structures like the one shown in Fig. 1.

For a part like that, the most critical requirements concern:

1. Surface roughness (SLM/DMLS guarantees "as built" surface roughness within the range of  $5.6 \div 7.2 \mu\text{m}$  Ra, meaning that several finishing processes are required to achieve at least  $1.6 \div 2.4 \mu\text{m}$  Ra)
2. Tolerances of 0.6mm
3. Part weight (the component must be positioned to allow the support structures to be perfectly removed during post-processing so that no residue will alter the weight. It is vital to establish the correct position for the part inside the melting chamber to avoid generating non-removable supports, particularly inside cavities that may be not accessible after printing is complete).

Motorsport and racing impose short lead times; this means that parts must be printed properly at the first attempt without distortions that generate scraps. This is the core challenge for both the manufacturer and for the simulation software, which must be able to model the melting process without excessive computing time.

### Optimization of the AM process

The optimization project described in this paper was produced by a team of experts – in materials (University of Modena and Reggio Emilia), in metal AM (Additiva), and in the virtual optimization of the AM process (EnginSoft).

The process to evaluate the best configuration for the part to be printed was developed as follows:

- Printing a reference shape and measuring the distortion to calibrate the model
- Executing a set of rapid simulations to identify the best orientation/positioning for the part inside the build platform
- Analysing the distortion tendency (maximum and average displacement)
- Analysing the process time

### A. Model calibration

In order to configure the 3D printing machine set-up and the laser parameters identified to melt the aerodynamic wing part, a cross-shaped sample was printed using an M2 CONCEPT LASER system. This sample was measured to establish its deviations from the nominal ones used by the software in order to calibrate the model's response.

This approach is used in the preliminary stages of modelling to accelerate computing time while ensuring that the model suitably represents the process.

### B. Orientation and positioning

Four positions were developed for the part, as shown in Fig. 2. Two of them (2 and 3) were selected to minimize the printing time (minimum job height), while the other two (1 and 4) were expected to result in a minimum mass for the supports in the critical areas of the part.

The software enables the maximum displacement of the part to be estimated, and the areas where that distortion is expected to be identified. Table I summarizes the results of this screening phase (the qualitative levels of distortion and the workload necessary to remove the supports were assessed by the manufacturer based on experience).

Orientation no. 2 had the maximum expected displacement, while Orientation no. 3 had the minimum. Orientation no. 3, however, would require a high mass of support structures that would be difficult, or even impossible, to remove. While the internal support structures could be left inside the cavities, this would unacceptably increase the weight of the part. Consequently, Orientations no. 2 and 3 were discarded and not investigated further.

Orientation no. 1 showed a maximum displacement that was higher than the one of Orientation no. 4, yet Orientation no. 4 had the maximum height in the Z axis, leading to greater printing time and cost. This simplified model showed that neither Orientation no. 1 nor no. 4 fulfilled the design requirement of a maximum distortion of less than 0.6mm.

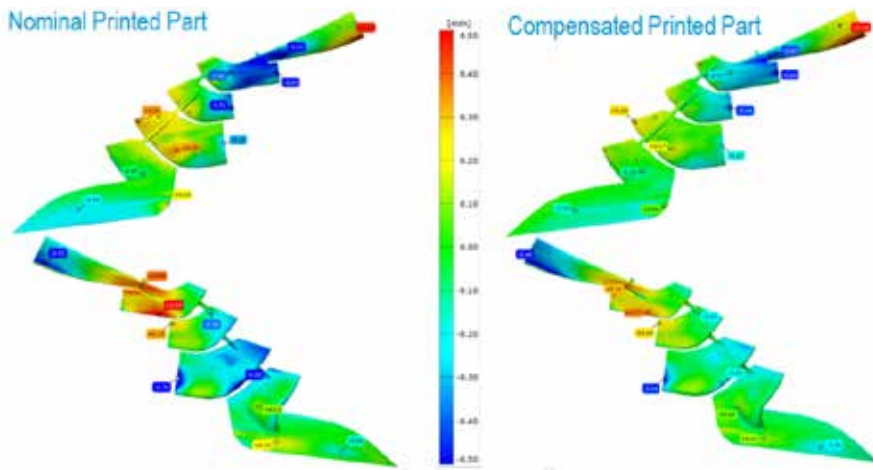

Fig. 5. Distortion comparison between the nominal part (left) and the compensated part (right).

When considering both the manufacturing times and the distortion tendency, however, Orientation no. 4 was the most promising candidate for printing: the increased printing time did not cause consistent variations in the total production cost, and the primary purpose of the project was to reduce the number of deformations.

### C. Analysis of the distortion tendency

The third step consisted of developing a compensated geometry. Ansys Additive Suite simulates the laser melting process, predicts distortions, and develops a new compensated geometry by reversing the distortion effects. The melting of this new compensated geometry should significantly reduce the distortions, resulting in a part as close as possible to the original 3D model.

Fig. 3 shows the new compensated geometry. A maximum displacement of 0.70mm was observed on the red surface. The slight difference from the analysis described in (B) was due to the simulation assumptions: in this case, to obtain a better estimate of the distortion, a finer mesh was used in addition to the actual scan pattern.

The part was printed using both the uncompensated geometry (not shown) and the compensated geometry for Orientation no. 4 (Fig. 4). 3D optical scanning was used to measure the surface of the part in three scenarios: after the melting process (with parts and support structures still attached to the build platform); after stress reduction;

and after removal of the supports. The results of the dimensional measurements, shown in Fig. 5, are in agreement with the simulation result in terms of position, maximum and minimum deviation from the nominal values, as well as the tendency towards improvement by moving the solution from four different orientations.

The comparison between the simulation results and the 3D scans of the printed parts clearly shows how it is possible to obtain an accurate output through simulation, which can predict the location of the maximum distortions in the upper part of the component.

Just from the preliminary simulations, it was possible to keep the maximum distortion below 0.59mm. Compensation further improved the quality of the part, with a maximum displacement of 0.48mm and a lower average and standard deviation of the absolute value of the distortions.

These results were achieved with a single simulation iteration; better results could be achieved with more iterations in order to better estimate the effects of distortion, and thus generate a more effective compensated geometry.

### Conclusions

Metal AM allows new complex parts to be designed and produced in a very short time. This is particularly true in demanding fields like motorsport and racing, where mechanical properties (elastic modulus and strength) are mandatory, with minimum manufacturing

times to rapidly introduce new solutions for each race. This project has shown that it is possible to print complex parts that conform to design specifications through a correct understanding of the SLM/DMLS process and the use of simulation tools.

Through rapid simulations on simplified models, it is possible to study the effects of different part orientations and to identify the most promising one in terms of the distortion tendency. This also makes it possible to identify areas affected by high displacements and, if necessary, to locally modify the support structures.

Using a more accurate model, it is possible to predict the distortion range and generate a compensated geometry that allows parts closer to the nominal geometry to be manufactured. This approach has the potential to further extend the DfAM field, including not only classical topological optimization, but also the design of parts and processes that minimize residual stress or distortion.

### Acknowledgments

The authors would like to express their deepest appreciation to the collaborators and technical staff who helped us to complete this project. Special gratitude goes to the RENAULT F1 Team whose contribution was fundamental in managing and disseminating the project.

Article from:  
*EnginSoft Newsletter* Year 17 n.2  
Summer 2020

### References

- [1] ASTM Standard F2792, 2012a, "Standard Terminology for Additive Manufacturing Technologies," ASTM International, West Conshohocken, PA, 2012, DOI: 10.1520/F2792-12A.
- [2] S. Liu, Y. C. Shin "Additive manufacturing of Ti6Al4V alloy: A review", *Materials and Design* 164 (2019) 107552

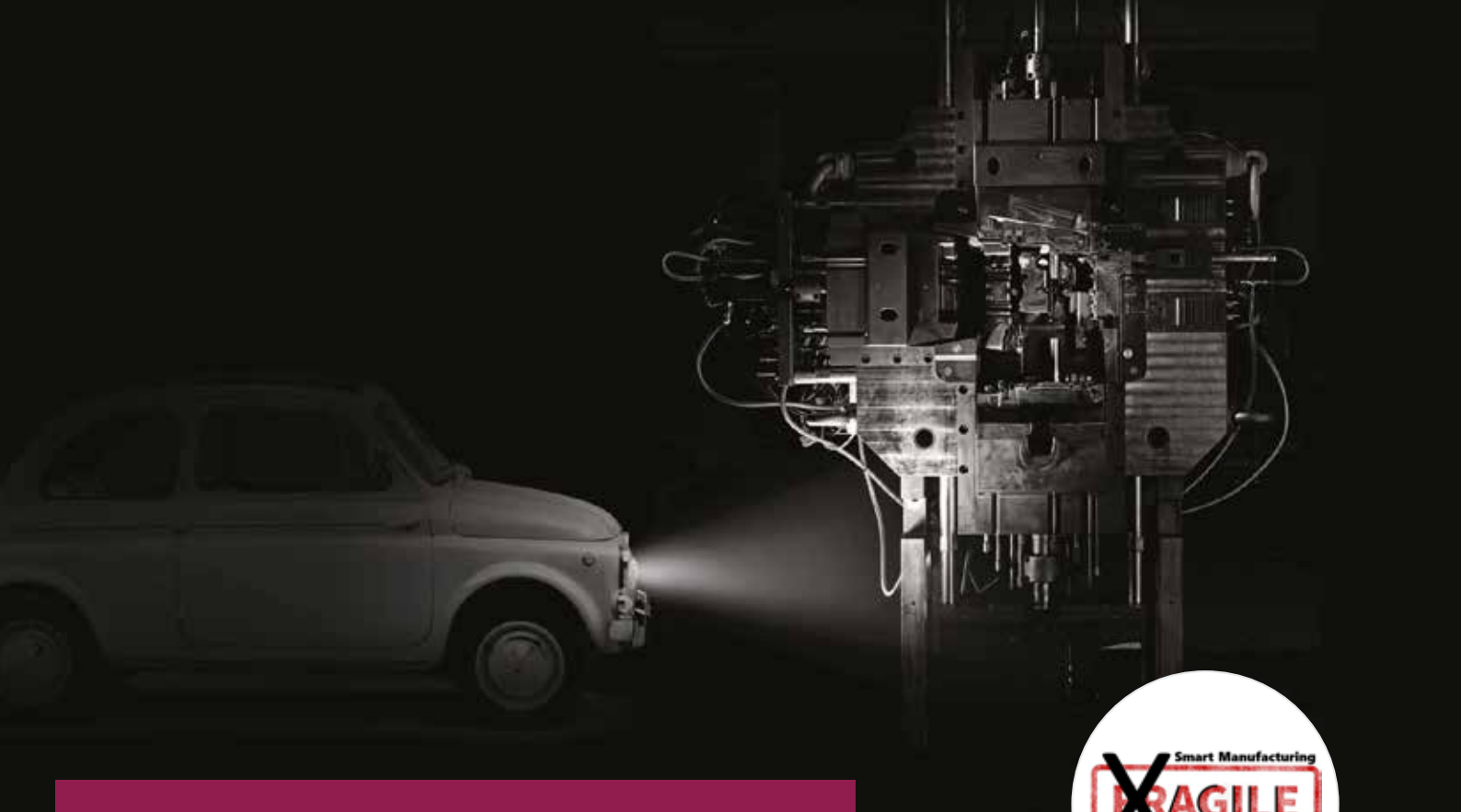

# Design and impact assessment of a die-casting insert made with Additive Manufacturing

by Filippo Voltazza<sup>1</sup>, Stefania Bruschi<sup>2</sup>, Rachele Bertolini<sup>2</sup>, Nicola Gramegna<sup>3</sup>, Giampietro Scarpa<sup>3</sup>

1. Saen - 2. Università degli Studi di Padova, DII - 3. EnginSoft

The challenges for the manufacturing sector, and in particular for the light alloy die-casting sector, are manifold. Being competitive in dynamic environments requires rapid product innovation and consequently, the rapid adaptation of production systems. A structured, integrated and easily reconfigurable system is required to create more responsive and agile production lines which integrate with robust supply chains that supply the necessary materials, tools, and resources to respond effectively to emergency situations such as pandemics. A good example is an additive manufacturing system that enables both the production of small batches and the ability to make rapid changes to dies and tools in response to individual customer demand or to replace damaged parts. A high-quality agile production system must guarantee the reliability and performance of the products it produces before they are sent to market. Lastly, an efficient and safe production line requires the rapid reconfiguration of processes in order to maintain extreme competitiveness with equivalent quality/functionality and work security.

In response to these challenges, this paper presents a summary of some of the significant results obtained in the metallurgical part of the Veneto region's AGILE project. Digitalizing the design phase transforms, systematizes, and virtualizes design, making it faster and

more flexible and enabling it to become a company "asset" that can be improved as contexts and scenarios change, all of which strongly support competitiveness.

The solution described in this paper was introduced into one of the aluminium alloy high-pressure die-casting (HPDC) foundries of one of the project partners (Saen) and used various simulation tools to redesign both the HPDC process and a die to accommodate the insertion of an insert with conformal channels made with additive printing in H13 steel. The die-casting simulation optimized the shape of these channels and of the process parameters in order to maximize heat removal in the massive zone of the casting, thus reducing the risk of defects. At the same time, the simulation enabled the prediction of the thermo-mechanical behaviour of the insert, and of the entire mould, both of which are crucial for estimating the fatigue life of the insert itself.

## SCOPE OF THE PROJECT

### Agility in high-pressure die-casting (HPDC)

The foundry sector, and particularly the die-casting sector, has undergone an evolution over the last ten years that is gradually transforming it into Foundry4.0, and increasing numbers of the



enabling technologies of Industry4.0 are being integrated into the design and management of production systems.

It is widely acknowledged that the heart of die-casting lies in the mould or die that, together with the press, represents the essential equipment necessary to mass-produce numerous light alloy castings. Notwithstanding the consolidated use of simulation in the design phase, and a marked increase in process control, the agility of the die-casting process is significantly affected by slow product-code changes, the inability to economically produce small-batch production runs, and the lack of intelligent tools to control production and final quality: all aspects that were made even more apparent by the pandemic.

There are four strategic approaches that can be taken to create a highly automated yet highly operator-dependent and mass-production-friendly process more agile:

- The virtualization of the design phase transforms, systematizes, and virtualizes design, making it faster and more flexible and enabling it to become a company "asset" that can be improved as contexts and scenarios change, all of which strongly support competitiveness;
- The implementation of advanced and high-speed manufacturing technologies, such as additive manufacturing (AM), that allow completely new components or totally reconceived equipment and/or parts to be produced quickly and easily;
- The rapid reconfiguration and optimization of the production process by rendering equipment and process parameters as flexible as possible;
- Intelligent quality management focused on zero defects but with increased attention to productivity, tool life, and time to market.

Broadly speaking, "agility" should increase the skills, boost the production, and enhance the market competitiveness of all the companies in the light-alloy foundry industry, Italy's leading production sector in Europe.

### Design of an HPDC insert with conformal cooling channels

Issues of thermal fatigue and the consequent damage to the die, and deteriorated casting-surface quality, or alloy-to-mould bonding, which requires an interruption of the production cycle for maintenance, are more likely to occur in zones where it is more difficult to thermally control the mould.

The use of "plugs" and "inserts" to maximize mould life and productivity was introduced some time ago. These are components, frequently made of higher-quality materials that better resist thermal stresses, which are incorporated into the mould. Plugs and inserts are generally produced by machining from bar stock, but this approach limits the ability to implement and/or optimize internal cooling circuits.

The recent growth in interest in the use of Additive Manufacturing to create these inserts and/or plugs is therefore easily understandable, particularly considering that AM guarantees two options:

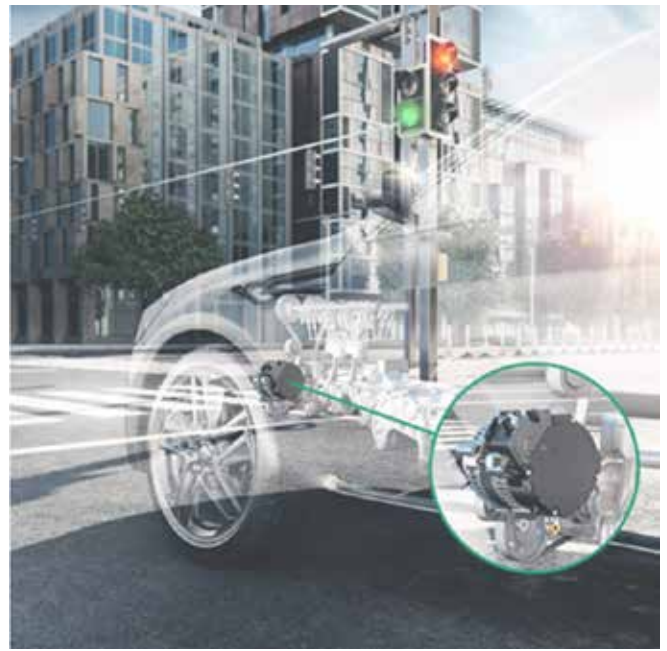

Fig. 1. Test case: SEG Automotive's Boost Recuperation Machine (BRM) system – one of the leading 48V machines on the market and already deployed in over one million vehicles on the road across the globe.

- the use of selected, high-performance materials where they are most needed while continuing to make the other parts of the mould with more conventional steels and materials;
- the creation and inclusion of "customized" cooling circuits to optimize the operation and duration of the entire mould, as well as to ensure the consistent quality of die-cast products.

The features of SEG Automotive's BRM system can be summarized as follows:

- It allows rapid, silent, immediate, and reliable engine start;
- It stores charge in a 48V battery from which it provides the electricity to power the car's 12V systems via a DC/DC converter;
- The kinetic energy created by braking is converted into electrical energy and stored in the battery;
- During acceleration, it provides additional torque to the thermal engine;
- At constant cruise speed, the BRM system maintains the vehicle's speed with the engine off in "free-wheel" mode and consuming zero fuel;
- Upon renewed acceleration, the system instantly starts the engine;
- Traditional start-stop functionality.

The cover/housing product development phase involved an initial numerical simulation that was conducted with MAGMASOFT, after which some die-cast prototypes were produced. These processes revealed some critical issues in the porous zones where the BRM attaches to the engine. To reduce the incidence of the problem, we studied an insert with specially designed thermoregulation channels to be inserted in the critical area. Thermal simulations were used to define these thermoregulation circuits (see Fig. 2). The small insert (30mm x 30mm x 60mm) was optimized by developing specific

geometries for the thermoregulation channels that are impossible to achieve with traditional machining. AM technology, however, allowed us to create channels with extremely narrow diameters (2mm) and curved flow trajectories, “free” from any of the restrictions of traditional machining. This enabled us to significantly optimize the insert’s conditioning effect in the critical area.

The plug’s thermo-fluid dynamic function must maximize heat extraction from the casting as it solidifies during the die-casting production cycle and also consider the production rate of the system that determines the quantity and potency of the thermal shocks created, which can limit the fatigue strength of the casting.

To achieve the twofold objectives of reducing defects and increasing the life of the insert, we used MAGMA5 software simulations under steady-state thermal conditions to replicate those of actual production (Fig. 3) to support the design of the die.

The simulation of the die-casting process considered all the injection parameters and all phases of the production cycle, perfectly replicating real production. The plug, redesigned to be inserted into the mobile matrix, was studied in four potential configurations with increasingly complex and effective cooling (Fig. 2). The shapes with more or less compact spiral circuits (v03 and v04), take full advantage of the freedom offered by additive printing and provide significantly superior fluid-dynamic performance (Fig. 5) compared to the plugs without cooling (v01) or with only a simple central cooling fountain (v02) that were used as references for suitable correlation.

The comparison considers the water-cooling circuits of the block that operate at an initial temperature of 30°C and a flow rate of 25 litres/minute. This made it possible to identify the greater cooling efficiency achieved by the conformal cooling compared to traditional technology and drastically reduces the thermal shock to the block thereby guaranteeing greater production longevity.

The fluid dynamics analysis conducted on the circuit verified the superior performance

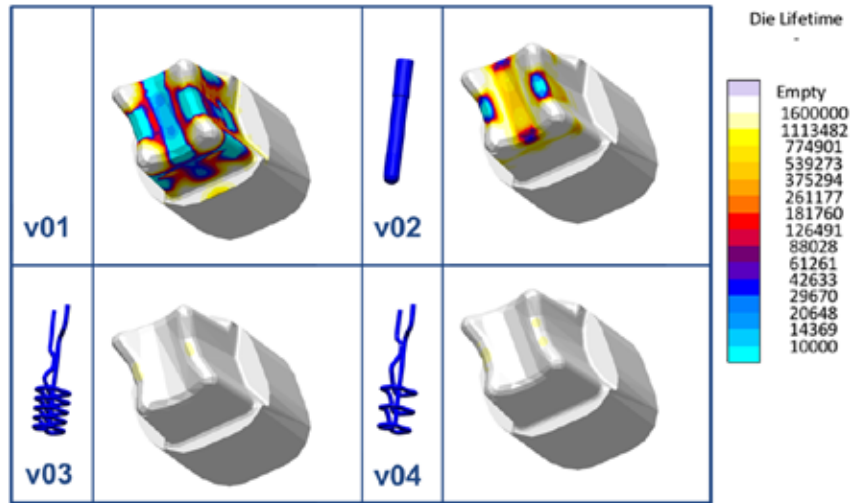

Fig. 2. Study of special thermoregulation system using MAGMASOFT.

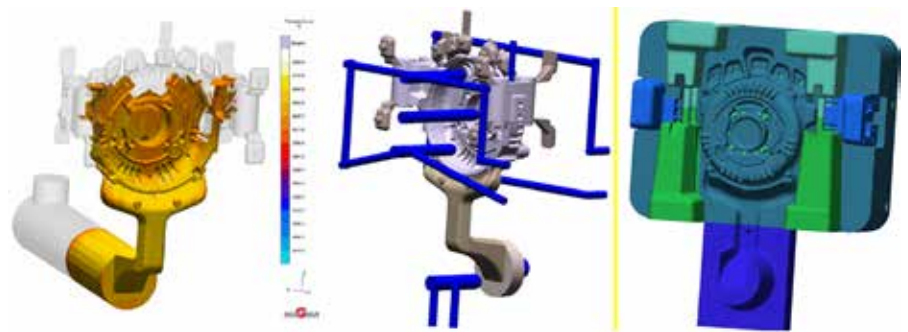

Fig. 3. Simulation of the thermal process.

in terms of temperature, speed, and heat exchange (HTC) (Fig. 4). Both the parameters used, and the geometric shape of the circuit guarantee remarkable stability and constancy throughout the flow circuit. Most importantly, the analysis verified that the thermal degradation between the inlet (30°C) and the outlet (30.1°C) is practically zero, indicating maximum efficiency. This result was ensured by the high flow velocity of the cooling fluid within the circuit and as expected, heat exchange (HTC) is particularly high throughout the circuit, ensuring the plug’s remarkably effective temperature regulation.

A plug with conformal cooling circuits and large coils (Fig. 4), was finally selected for production using additive technology; this geometric shape also facilitates the production of the insert itself and powder removal after 3D printing. The chosen configuration was finally verified in detail by simulating the thermal conditions during cyclical repetition of the filling and solidification phases of casting. The analysis of the filling and solidification dynamics highlighted the potential formation

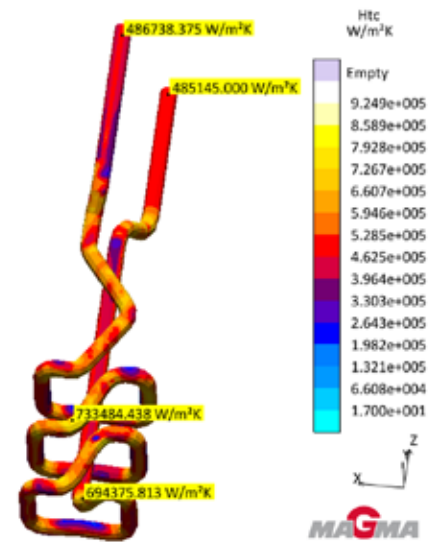

Fig. 4. Fluid dynamics study in terms of heat exchange.

of residual porosities from air entrapment and shrinkage, particularly in the massive lateral parts of the component (Fig. 5). Fig. 5 shows the distribution of air envelopes (blue) and shrinkage porosities (red) in the right-hand area of the casting. A comparison of this analysis with an analysis of the actual quality using X-ray analysis and destructive testing highlighted the effective correspondence of the defects. This suggested that the shape

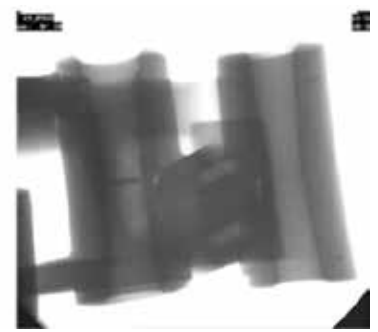
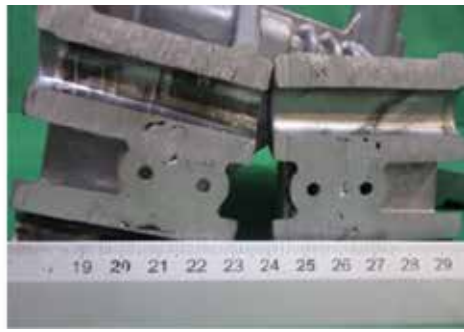

Fig. 5. Detail of predicted porosity defects due to shrinkage and air entrapment compared with X-ray analysis and destructive testing.

of the casting should be modified to obtain a completely soundness casting.

The thermal analysis of the plug also confirmed the minimal temperature difference (less than 60°C) before and after the lubrication phase, which guarantees a much longer thermal fatigue life (Fig. 6) than the current 150,000 cycles – an estimated increase of 120%. Lastly, the simulation also revealed a potential reduction in the cycle time thanks to the shorter solidification times of the massive area around the insert.

### Simulation of the additive manufacturing process

The creation of dies or parts thereof using additive technology is nothing new; there are numerous applications for plastic injection moulds, and these have also emerged in die-casting and over the last ten years [1-5]. Additive printing of metal alloys is undoubtedly an agile and effective solution for quickly obtaining a plug of the desired shape for better heat removal thanks to the shaped circuits. Obviously each plug, like the one in the case in question, must be made with machines, powders, and process parameters that have been appropriately calibrated and configured to produce a plug of the required density, shape, and size.

The simulation of the AM process made it possible to calibrate the material model based on printing tests and simulation of ad-hoc samples, suited to applications in hot working equipment, and to study the orientation and the supports necessary for 3D printing in order to obtain a high-quality moulded insert at the first attempt. Like the simulation of the die-casting process, the simulation of the L-PBF 3D printing process also aims to numerically solve all the

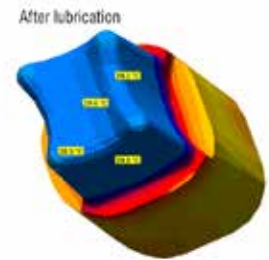
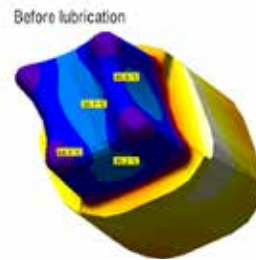
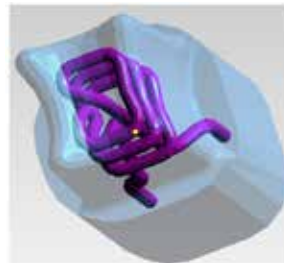

Fig. 6. Thermal analysis of the plug surface.

processes and metallurgical phenomena that occur during the laser sintering of the metal material deposited in powder form.

The targeted fusion determines the melt pool and the sequence of the deposited layers, while the path of the laser affects the size of the different melt pools that overlap and cool rapidly. A thermomechanical analysis follows the evolution from liquid to solid to predict the stresses and deformations generated at each layer and consequently within the final as-built state. The orientation and print layout, like all machine parameters, are inputs to the simulation which aims to virtually investigate the ideal setup required to obtain a complete and dimensionally correct part for the post-processing phase.

The cross-section and layout of the shaped channels designed to maximize the fluid dynamic efficiency for cooling the plug must be self-supporting during printing to avoid the use of supports inside the channels and to ensure that any residual non-sintered powder can easily be removed. Even though the insert in this study is compact and the ideal orientation for its printing is well known, all possible orientations were studied. These simulations provided useful results regarding the stability of the channels and the optimization of the printing parameters for the H13 material.

### Calibrating the material model

Since the temperature-dependent thermo-mechanical properties of the H13 material were not available (because the temperature varies), it was decided to use an elastic-plastic material model with the same mechanical properties as this type of steel so that an inherent strain simulation could be performed. This method allows the powder bed additive process simulation to be performed as a purely mechanical (structural) simulation based on the base material's mechanical properties in as-built conditions, and on a calibrated material model of the intrinsic characteristic deformation (inherent strain) deriving from the nature of the process itself and from the setup used (hardware, process parameters, scanning strategy, etc.).

To determine the inherent strain value, most commercial software requires the user to print calibration specimens designed to distort significantly, such as a cantilever of the type shown in Fig. 8 which facilitate distortion measurements. The first activity therefore consisted of creating the material model containing the physical and mechanical properties of the alloy in its as-built condition, i.e. after printing.

These properties (listed below) were found in the literature and converted into true values

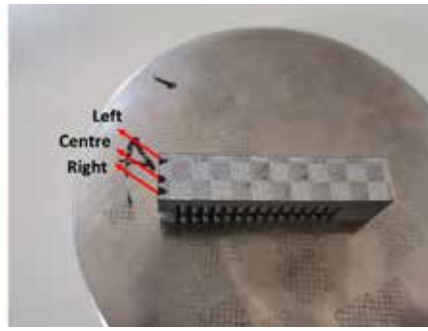
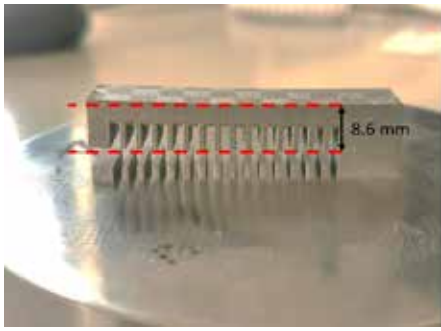

## Print simulation of insert

Once the material model is calibrated, the additive process simulation verifies the quality of the virtual prototype using the already optimized printing parameters (Table 1).

The simulation was performed by discretizing the insert in tetrahedral finite elements with an intermediate node (quadratic formulation), which provides a good representation of the geometric features of the component and facilitates the next steps of post-processing and analysis of the results (distortions and residual deformations/tensions). The supports, on the other hand, are made homogenous using linear hexahedral finite elements. The actual amount of material contained in each one is considered by means of a knockdown factor for the mechanical properties. The discretization is obviously a layered mesh, in the sense that the geometry is subdivided into layers of finite elements, in this case all having the same thickness of 0.4mm. Considering that the actual component will be moulded in 20µm layers, this means that 20 layers of cast material are packed into one layer of finite elements.

The results of the preliminary simulations performed with Ansys Additive Print are shown below in terms of distortions, or rather, displacements (relative) to the simulated nominal (the blank), as well as other significant quantities depending on the magnitude. All results are in the as-built condition immediately after printing with the part still joined to the platform.

Optical scanning and CT analysis of the as-built plug confirmed the predictions produced by the simulation with Ansys Additive suite.

Fig. 7. Cantilever beam after being partially cut from platform (source: UNIPD\_DII).

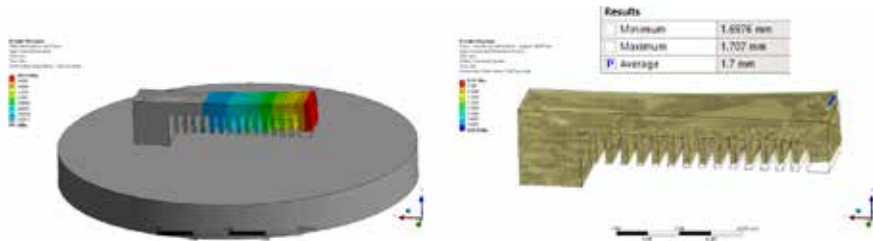

Fig. 8. Z-directional strain of the specimen and calibration of the SSF coefficient.

(true stress, true strain) to create the material model in Ansys Workbench:

- density,  $\rho = 7800\text{kg/m}^3$ ,
- elastic modulus,  $E = 215\text{GPa}$ ,
- poisson's ratio,  $\nu = 0.3$ ,
- yield strength  $\sigma_y = 1512\text{MPa}$ ,
- tensile strength  $\sigma_u = 1894\text{MPa}$ ,
- maximum elongation of 10% (0.1mm/mm).

The calibration procedure involves the creation of specimens (cantilever beams) using the standard scanning strategy that will then be used for the creation of the product. In order to improve the statistical analysis and limit the influence of manufacturing defects it was decided to make several specimens of which at least three were investigated. Once the specimens were made, they had to be partially

cut from the platform while leaving intact the thicker section of the tack connecting them to the platform (Fig. 8). The measurement of the Z-dimension at the upper end of the bar tack is used for calibration by comparing it with the simulation values.

Calibration using the measured experimental results is achieved by repeating the simulations and adjusting the calibration factor (Strain Scaling Factor – SSF) to achieve convergence with an acceptable level of error between the measured and simulated distortions at a value of 1.7mm (Fig. 7). This procedure was performed using two products in the Ansys Additive suite, namely Ansys Workbench Additive with an optimal SSF of 0.41005, and Ansys Additive Print with a calibrated SSF of 0.434.

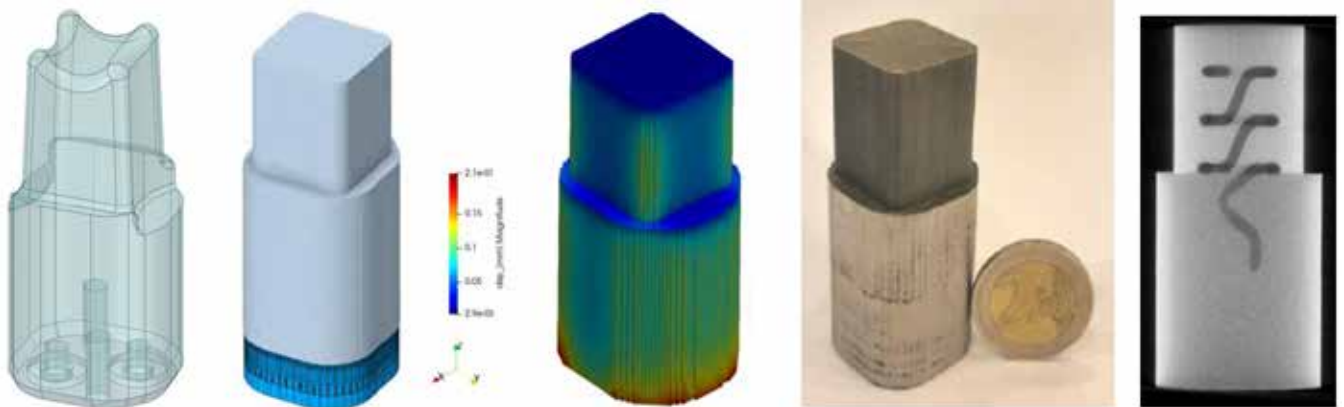

Fig. 9. Comparison of the blank of the insert and the print simulation (left). Insert manufactured using L-PBF parameters optimized by means of a preliminary experimental campaign and CT check of the moulded block (right).

### 3D-printing of the die insert

The steel powders for the H13 moulds were produced by Hogonas and supplied by MBN Nanomaterialia. The distribution of particles is shown in Table 1, following sieving after delivery, i.e. the dimensions of all the particles below 10%, 50% and 90% are indicated. The apparent density is 4.38g/cm<sup>3</sup>, and the density measured with a pycnometer is 7.73g/cm<sup>3</sup>.

	Delivered State	After Sieving
d10	33.3µm	29.6µm
d50	45.5µm	38.5µm
d90	62.0µm	50.0µm

Table 1. Distribution of H13 powder particles in the delivered state and after sieving

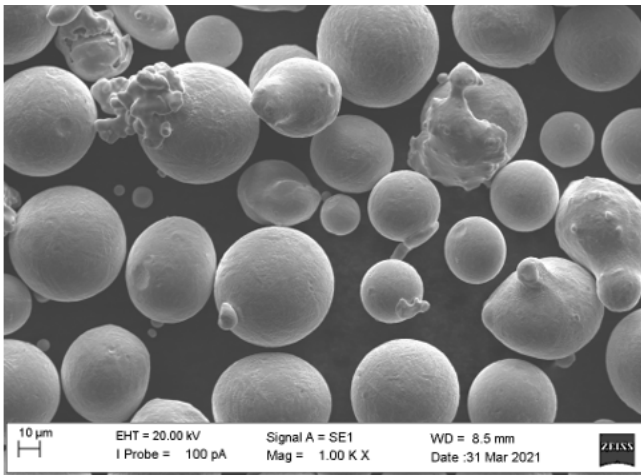

Fig. 10. SEM image of H13 powder after sieving.

Fig. 10 shows a scanning electron microscope (SEM) image of the powder particles after sieving: they have a rounded shape and sufficiently homogenous distribution to be suitable for the laser powder bed fusion (L-PBF) additive manufacturing process.

The L-PBF machine used to make the inserts is a Sisma MYSINT100 3D printer in the University of Padua's processing technologies and systems laboratory in the Department of Industrial Engineering (DII). This machine is equipped with a laser that has a 30µm spot diameter and a maximum power of 200W. Printing takes place in an argon-injected inert atmosphere to guarantee an oxygen content of less than 0.1%, thereby preventing oxidation of the powders.

An extensive experimental campaign (50 experiments) was conducted using a Design of Experiments (DoE) method to identify the optimal set of L-PBF process parameters. The layer thickness was kept constant at 0.02mm as was the laser spot at 30µm, while the laser power, scanning speed, and hatch spacing were varied as shown in Table 2. The output parameters chosen were surface roughness and density. Cubes with sides of 50mm were printed, an example of which is shown in Fig. 11.

The density of the printed samples was assessed according to Archimedes' method, favoured due to its simplicity, speed, and cost-effectiveness, using a KERN ABT 1205DM scale with a measurement

Laser power (W)	70->140
Scanning speed (mm/s)	300 -> 1000
Distance between tracks (mm)	0.05 -> 0.09

Table 2. L-PBF DoE plan



Fig. 11. Examples of samples printed using different L-PBF process parameters.

accuracy of 0.01µg. The surface roughness of the samples was measured using the Sensofar SNeox 3D optical profilometer. Given the high roughness of the samples, measurements were performed in focus variation mode using a 20x confocal lens. For each sample, a surface topography with an area of 3.68 x 3.2mm<sup>2</sup> was obtained for both the upper and lateral surfaces. Following the removal of the mould, the surface roughness (Sa) was assessed using ISO 4288.

A relative density of approximately 99.5% and minimal surface roughness on both evaluation surfaces was ensured by the following process parameters:

- laser power = 130W
- scanning speed = 600mm/s
- distance between traces = 0.08mm

These parameters were then used to produce the insert shown in Fig. 9. Following the 3D printing process, the heat treatment shown in Fig. 12 was used to obtain a comparable microstructure and hardness to that of conventionally manufactured H13 steel.

This treatment achieved a hardness that was only 5% lower at room

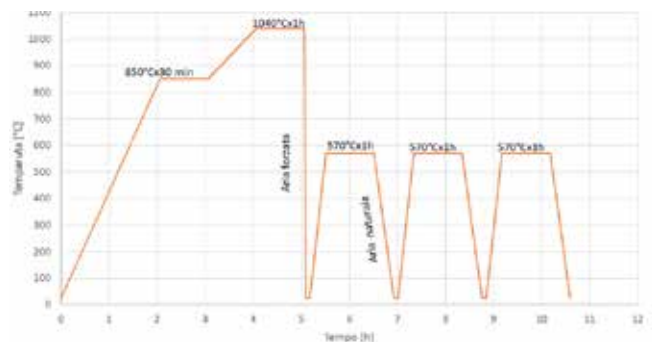

Fig. 12. Heat treatment after the L-PBF process.

temperature than that of conventional H13, and this difference was also maintained at 300°C, thus demonstrating that an optimized L-PBF process combined with heat treatment is able to achieve characteristics similar to those of traditionally produced steel.

### Implementation and testing of 3D-printed insert

Machining was performed with no problems and a surface finish comparable to traditionally manufactured and machined steel components was obtained (Fig. 13).

The machining and cutting parameters remained unchanged, enabling the final geometry to be produced promptly. No anomalous behaviour was detected at dimensional level either, as evidenced by the metrological checks performed.

Use of the plug during experimental foundry testing confirmed the efficiency of the thermoregulation system as well as the component's excellent thermal fatigue behaviour: no abnormal or early wear was found.

Analysis was conducted on the die-cast castings and on the pilot mould (a mould created for making die-cast prototypes), using CT scans and comparisons with the results obtained with traditional technologies for the former, and using thermal imaging cameras to monitor temperature trends in the plug area for the latter case.

In conclusion, additive manufacturing enables optimized and perfectly localized thermoregulation geometries to be designed, free of the limitations of traditional manufacturing technologies. This allows the best possible metallurgical results to be achieved for a predefined casting geometry that cannot be further optimized.

### Conclusions

The AGILE Project [6-7] emerged from discussions among a group of companies and research organizations based in the Veneto region in the post-pandemic-emergency period and aims to improve the region's industry's ability to convert their production systems in an "agile" manner using advanced solutions for product innovation.

The project falls under the Veneto region's "Smart Manufacturing" specialization strategy within the broader context of business competitiveness for Industry4.0 and represents an organized "industrial reaction" to the Covid-19 emergency characterized by flexibility, reconversion, and resilience.

More specifically, the project develops agile manufacturing solutions and tools to increase competitiveness and product innovation by targeting four areas of development:

- virtualization of the design phase,
- development and industrialization of advanced and high-speed production technologies,
- rapid reconfiguration and optimization of production lines, and
- intelligent quality management.

The AGILE Project focuses on specific, representative types of



Fig. 13. Completed plug after machining.

production lines in the Veneto region, and this paper describes the results achieved in High Pressure Die-Casting (HPDC).

Blending two technologies, die-casting, and additive manufacturing, made it simpler and easier to flexibly adjust and improve die performance and casting quality. The virtual design provided useful guidance for optimizing the shape of the thermoregulation circuits of the plug, which was then virtually inserted into the mould to predict its thermo-fluid-dynamic behaviour under thermal conditions typical of HPDC production. Likewise, the simulation of the 3D printing process ensured the highest quality of the 3D printed plugs from the very first print, after which they were machined and inserted into the die for the final test in production.

The MAGMA simulation software allowed the qualitative impact of different thermoregulation configurations on the die-casting process to be quickly compared, while the simulation of the AM technology with Ansys Additive suite enabled the designer to freely create the geometry that would yield the best results.

The technological development of 3D printing systems and the ability to use base powders made of the same materials as those used for traditional production of die-casting moulds provides the following benefits:

- Reduced die-casting costs in terms of materials and machining;
- Shorter lead times for manufacturing of components due to the use of AM;
- Consistent implementation of the best thermoregulation according to the customer's requirements and on the basis of numerical simulation findings;
- Decreased cycle times resulting in lower costs and increased competitiveness;
- Reduced scrap due to the improved casting quality;

- Lower energy consumption thanks to the reduced cycle times, fewer scrap castings and therefore less need to recycle them.

## Acknowledgements

The AGILE Project (ID No. 10300304) was financed by the Veneto region of Italy within the framework of its POR-FESR Programme 2014-2020. The following partners participated in the AGILE Project, coordinated by the SPRING Consortium: Zanardi Fonderie, Saen, Ecor International, AM Teknostampi, EnginSoft, Delka, Promotec, GOM Italia (ZEISS Group), UNILAB, MBN Nanomaterialia, University of Padua (DTG and DII Departments), CNR (ICMATE Institute).

For more information:

Nicola Gramegna - EnginSoft  
n.gramegna@enginsoft.com

This article will also be published in  
*Futurities* Year 20 n.4 Winter 2023

## References

- [1] J. K. Pancholi, B. Padhiyar, V. Sutariya, and H. Pancholi, "Design and Analysis of Die Casting Die with Conformal Cooling Channel", *International Journal of Engineering Science and Computing*, March 2019
- [2] L. Shu, Z. Zhang, Z. Ren, and T. Zhang, "Design and simulation of conformal cooling for a die-casting mold insert", *Journal of Physics: Conference Series* 1939 (2021)
- [3] G. S. Phull, S. Kumar, R. S. Walia, "Conformal Cooling for Molds produced by Additive Manufacturing: a review", *International Journal of Mechanical Engineering and Technology (IJMET)* 9: 1, January 2018, pp. 1162–1172, Article ID: IJMET\_09\_01\_124
- [4] M. S. Shinde, and K. M. Ashtankar, "Additive manufacturing–assisted conformal cooling channels in mold manufacturing processes", *Advances in Mechanical Engineering* Vol. 9(5) 1–14, 2017
- [5] P. Cicconi, M. Mandolini, F. Santucci, and M. Germani, "Designing die insert by additive approach: a test case", 31st CIRP Design Conference 2021 (CIRP Design 2021)
- [6] N. Gramegna, and F. Bonollo, "Challenges and Benefits in AGILE manufacturing applied to metalworking production processes", 39° Convegno Nazionale AIM, September 2022, Padua, Italy
- [7] F. Bonollo, N. Gramegna, and G. Timelli, "Smart Factory Competitiveness based on real time Monitoring and Quality predictive model applied to multi-stages Production lines", in *Advances in Production Management Systems. Towards Smart and Digital Manufacturing* by B. Lalic et al (eds), APMS 2020. *IFIP Advances in Information and Communication Technology*, vol 592, (pp.185-196), August 2020, Springer, Cham. [https://doi.org/10.1007/978-3-030-57997-5\\_22](https://doi.org/10.1007/978-3-030-57997-5_22)

## AIM's Powder Metallurgy and Additive Technologies Centre

AIM (Associazione Italiana di Metallurgia) is the technical-scientific association of reference for the Italian national metalworking industry. It was founded in 1946 for knowledge diffusion and to increase the use of metallic and other materials in engineering. Through its activities the association aims to promote the exchange of ideas and experiences between all those interested developing and deepening knowledge about metallic materials, and particularly between producers, processors, users and researchers as members of the supply chain.

One of its first committees was the Powder Metallurgy Centre, established in 1959, which aims to create a bridge between the academic world and the various industrial players in the metal powder production chain. Since its inception, the Centre has actively disseminated knowledge on the production, use, and processing of metal powders, and has promoted applications for sintered materials. Through its authoritative and prominent members, the committee has been able to record and contribute to developments in the various sectors preparing sintered products. These include developments in the quality and available types of powders, increases and improvements in press productivity and the development of new models such as electric presses, as well as consolidating the reliability of sintering plants and final treatments. These activities have increased the diffusion of sintered parts in industry and have promoted an increasingly strong cultural and technical awareness of the potential in re-designing certain parts previously produced with so-called traditional technologies. At the same time, the increased use has incentivized ongoing study and development of new, increasingly high-performance solutions.



**ASSOCIAZIONE  
ITALIANA DI  
METALLURGIA**

Italian industry has always held a prominent position internationally and consequently committee members have always focused on the internationalization of the contributions aimed at developing Italian manufacturing in an increasingly borderless context. Accordingly, events organized in the 60-plus years of the Centre's existence have featured European speakers and likewise committee members have presented in international arenas. Over the years, new technologies have been developed and added to traditional pressing and sintering in furnaces, namely the MIM process (since the early 1980s), plasma sintering (2000s), and more recently the family of additive technologies. It is the latter group that has increasingly attracted the attention of the scientific and industrial community due to its undoubted ability to propose highly innovative solutions in multiple fields. The committee, therefore, being sensitive to technological innovations and changes, adopted the name Powder Metallurgy and Additive Technologies in 2017. The new name of the committee clearly reflects the spirit of its members who believe strongly in the value of traditional technologies, in the importance of innovating in even well-established processes, and simultaneously in disseminating technical-metallurgical knowledge in new areas in order to increase skills and actively attract new players.

The committee offers numerous training and refresher courses dedicated to Additive Manufacturing amongst which the six-monthly Additive Metallurgy Course is very popular. The complete list of activities and publications is available at: [www.aimnet.it](http://www.aimnet.it)



# Tita-Banti's Olympic catamaran keeps flying thanks to 3D printing from the ProM Facility

by **Gabriele Nicolussi**  
Trentino Sviluppo

Gold at the Tokyo 2020 Olympic Games, powerful European gold in Aarhus in Denmark, and unchallenged dominance at the World Championships in Nova Scotia in Canada: astonishing results for the Italian sailing duo, Ruggero Tita and Caterina Banti, who "fly" on their Nacra 17 catamaran with an increasing number of Made-in-Trentino components. After their Olympic triumph the team, represented by the helmsman Tita who is from Cognola in Trento, renewed their cooperation with the ProM (Prototyping Mechatronics) Facility, a laboratory in the Polo Meccatronica hub in Rovereto in Trentino in Italy.



The ProM Facility developed new customized, high-tech components in titanium and plastics, which were then built using state-of-the-art technologies such as 3D printing of metals and polymers and X-ray computed tomography. Another key element in the validation phase of the parts was the use of Ansys software provided by EnginSoft, which allowed detailed mechanical and fluid-dynamics simulations to be conducted. The duo's synergetic relationship with the ProM Facility has grown considerably over the years and has made the Italian team's Nacra 17 the fastest and most innovative boat in the world in its category.

## A winning combination

Tita and the ProM Facility began working together in 2019 to meet a specific need, namely to make the boat as light as possible in order to face the challenge of Tokyo 2020 in the best possible shape and to take the top position on the podium. The Nacra 17 is a one-design catamaran, which means it is produced the same way for everyone and does not offer many possibilities for design changes that could make it more competitive. Working on those few areas where improvement is possible makes a big difference and allows the sailors to gain those fractions of a second that can guarantee victory. The Trentino engineers immediately took up Tita's challenge and focused on a single material and a specific technology: titanium, one of the strongest materials in



the world despite its very low specific weight, and 3D printing, perfect for designing exclusive or limited-edition parts. After winning Olympic gold, the champions immediately started working towards the 2022 World and European Championships. The main problem remained which components could be further improved to make the boat even more competitive.

### A titanium cleat with reinforced resin pulleys

A cleat is a self-locking device attached to a steel cable and a nylon lanyard that harnesses the helmsman to the boat and prevents him/her from falling overboard. Tita's main requirement was to redesign the component usually found on the market to make it smaller. ProM Facility engineers redesigned it and printed it in titanium (the original one is in steel), after reducing its volume by 63%. A texture was added to increase finger grip during use and a tab to make it easier to handle. The cleat also contains pulleys that help the nylon lanyard slide and have been 3D-printed in a special type of resin reinforced with ceramic microspheres.

Before being 3D-printed, the cleat model was subjected to various FEA (finite element analysis) tests using Ansys software; this allowed the engineers to define the stresses to which it would be subjected and the deformations it would undergo. The finished part was then bench tested using mechanical tests until the lanyards broke under a stress of approximately 600kg. This proved that the device is capable of bearing a greater weight than that carried by the lanyards to which it is attached.

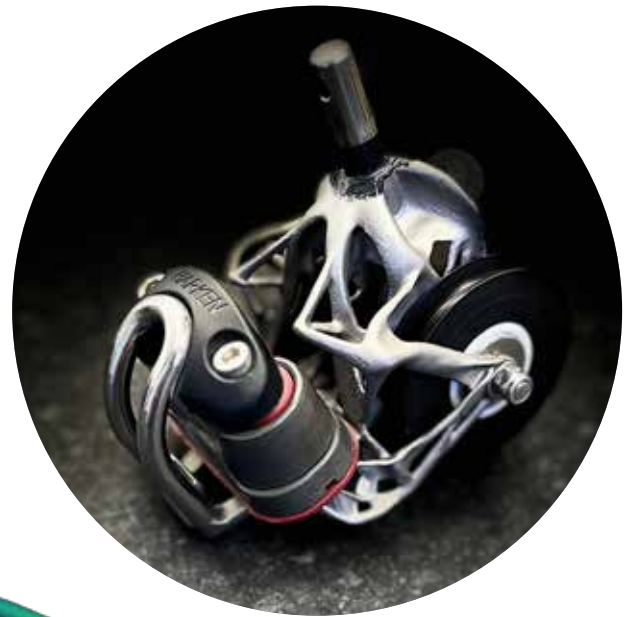
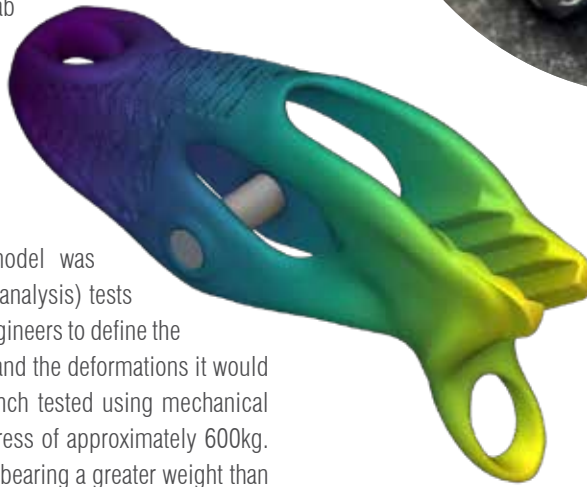

### Hoist carters made of PA12

One of ProM Facility's first achievements for Tita-Banti in 2019 was to redesign the boat's hoists and their carters to make them lighter and more aerodynamic. After the Olympics, the official parameters of the discipline changed and the main function of the carters ceased to be aerodynamics. The Rovereto-based laboratory therefore redesigned them from scratch, using a

more classic shape very similar to the original, and printed them in PA12, a plastic material known for its high resistance to strain. Fluid-flow tests show that this different configuration, while complying with the new regulations, also allows for good aerodynamics.

### The calibration tool

Before putting a boat with foils like the Nacra 17 into the water it is necessary to check that the foils that make the boat "fly" in the water are perfectly aligned with the hull. This is a very important and delicate operation that, if performed incorrectly, could compromise the crew's performance. Therefore, the ProM Facility's technicians together with Tita, developed a device that allows the angle of inclination of each individual foil to be checked quickly and easily using a laser level. This was also printed in PA12, like the carters. In a tool like this, precision is a key feature because even a single millimetre makes all the difference. The prototyping workshop of Trentino Sviluppo's high-tech hub also used X-ray computed tomography to check the flatness of the part, comparing it with the model created by the PC.

For more information:

Paolo Gregori - TrentinoSviluppo  
paolo.gregori@trentinosviluppo.it

## About ProM Facility

### ProM Facility: a technological bridge between research and enterprise

ProM Facility is a unique centre in Italy. Its mission is to develop, produce, and test innovative products capable of bridging the gap between traditional mechanics and the most advanced physical and virtual prototyping, testing and qualification systems. Its strength lies in its ability to bring together different enabling technologies of Industry 4.0, such as 3D printing, artificial intelligence, smart manufacturing, and control electronics, in a single laboratory. Over the past few years, it has operated in widely diverse sectors ranging from automotive to aerospace, and from biomedical to sports-tech. Hosted by the Polo Meccatronica in Rovereto in Italy, the creation of the facility in 2017 was spearheaded by the Autonomous Province of Trento, which aimed to systematize the services, skills, know-how and network offered by Trentino Sviluppo and its partners: the University of Trento, Fondazione Bruno Kessler, and Confindustria Trento. The Trentino workshop is part of the Digital Innovation Hub (DIH) and Competence Centre networks, and of the European 'Vanguard Initiative' network, in which it plays a formal role in the Pilot 3DPrinting Steering Committee.

For further information, visit: [promfacility.eu](http://promfacility.eu)

Article from: *Futurities* Year 19 n.3 Autumn 2022

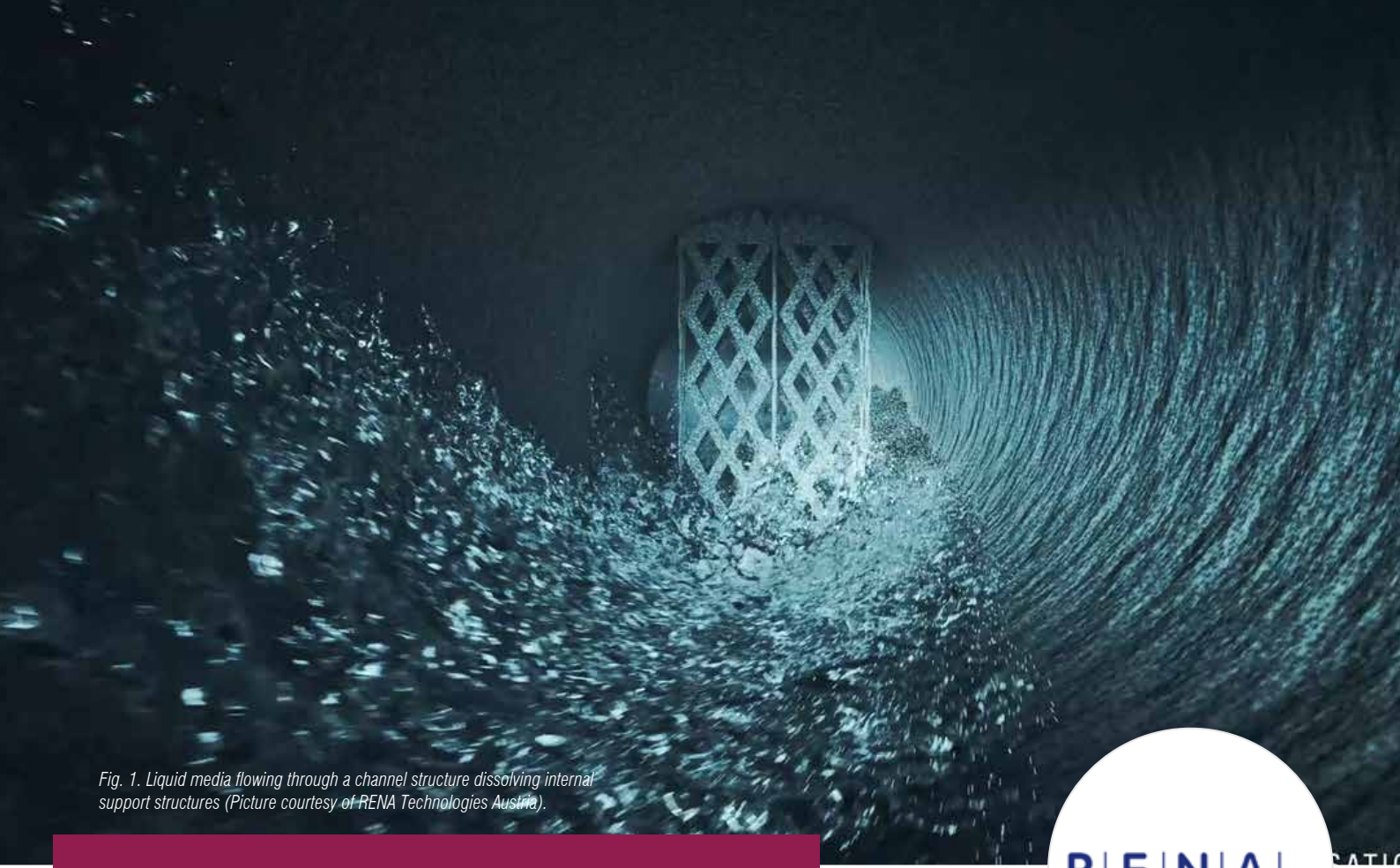

Fig. 1. Liquid media flowing through a channel structure dissolving internal support structures (Picture courtesy of RENA Technologies Austria).



## The power of liquid media for finishing 3D-printed metal parts

by **Wolfgang Hansal**  
RENA Technologies Austria

Additive Manufacturing (AM) with all the freedom it offers in part design requires new methods for post-processing printed metal parts. The design freedom is also used to create specific textures and lettering on the surfaces and to realize complex internal channel systems throughout the part. Mechanical post treatment routines in particular, as well as classical electropolishing, are not capable of finishing such internal structures. For this, post-processing methods are needed that distinguish the part from unwanted structures such as powder residues and supports. Modern electrochemical methods based on liquid media can help to overcome such limitations and enable appropriate post-processing, especially for internal channels and chambers.

Powder residues and laser marks are characteristic of the surfaces of additively manufactured metal parts. In addition, support structures and adhering powder residues must be removed in a first step. Without the removal of such undesirable features, the parts cannot be used

technically at all, since classical mechanical or "dry" methods are not able to penetrate deep into internal part features.

Printer manufacturers are looking for ways to realize completely support-free printing. This again comes with some geometry limitations. Some larger internal compartments and some channel structures still require supports. Does this mean that such geometries cannot be used in industrial production? Would this significantly limit the core feature of design freedom in 3D-printing? As Albert Einstein once said: problems can never be solved with the same thinking that caused them.

Design freedom is a core feature of additive manufacturing. It sets the process apart from other production methods and is its *raison d'être* as a new manufacturing technology. Enabling new multifunctionality and currently impossible design features (think of flow-optimized impeller geometries that cannot be produced by casting) gives metal AM its own place among competing manufacturing processes, even at significantly higher production costs. The possibilities are endless and are just beginning to be explored by scientists and engineers around the world.



Fig. 2. Cross-sections of a manifold used in automotive applications. The printed part (left) includes internal support structures that cannot be removed mechanically. In the finished part the support structures have been completely removed and the surface levelled. (Hirtisation® treatment, picture courtesy of RENA Technologies Austria)

Maintaining full design freedom does not mean avoiding support structures, but reliably eliminating them via finishing. The most complex parts require supports, and even if most of these can be avoided, their avoidance may be accompanied by an increase in printing costs. In industrial production runs, the price is crucial; any increase can make the run unprofitable. The solution to this problem lies in changing of the finishing method.

Internal chambers and channels can be easily reached by liquid media, even if they cannot be reached by mechanical means. When the power of active fluids is combined with the application of modern (dynamic) electrochemistry, the part can be surface treated wherever the fluid can reach the surface. The chemical-electrochemical approach dissolves the support structures as well as powder residues, and levels the surface. Fig. 1 demonstrates the treatment of internal channels including support structures by liquid media. By pumping the electrolyte through a channel system, this effect can be enhanced and/or accelerated. This does not require a high-pressure

## About RENA Technologies Austria

RENA Technologies is the global technological leader for wet processing equipment. We provide the most valuable, innovative wet-chemical solutions for our clients to reach the next level of state-of-the-art. We manufacture the highest quality flexible and high-throughput equipment in the semiconductor, medTech, glass, additive manufacturing and renewable energy sectors. RENA is the German acronym for Reinraum-Equipment, Nasschemie, and Automatisierung (cleanroom equipment, wet chemical, and automation) – the company's four core competencies. Together with customers from every sector of the semiconductor, medtech, renewable energies, glass or additive manufacturing sectors, RENA Technologies develops pioneering solutions for the production of premium-quality machinery for wet chemical surface treatment applications.

**RENA is an expert partner for your production solution.**

regime, but a slow, continuous flow. A prominent example of such post-processing based on dynamic electrochemical and chemical principles is Hirtisation®, which enables industrial post processing of complex component geometries – inside and out.

As with any post-processing, consideration should be given to this aspect early on within the file generation process. Post processing will not miraculously eliminate all problems, nor will it compensate for printing errors. It is only after post processing that a part achieves its final dimensions and not, as most users believe, after printing. Meeting the specifications of mass production requires guaranteeing certain final dimensions of the part when it reaches the (end) user. Machining or electrolytic dissolution reduces the part size a little.

Each finishing operation has its own characteristic method of material removal. This must be calculated when creating the print files. In addition, carefully coordinated process chains will increase overall production efficiency and thus lead to lower production costs. Closing the interface between printing and finishing can reduce the amount of post-processing required by up to 30%. Measures that can be taken to increase overall production efficiency include ensuring proper flow through internal channels and aligning support structures in the media flow direction.

A good example of the above assertions is a study of a manifold used in automotive applications. This part has a complex internal geometry with widening channels and a larger central compartment. It requires internal support structures for the printing process, and its design does not allow for classical, mechanical post-processing. For demonstration purposes, a part was cut in half before post-processing was applied. The internal channel structures and the support structures are clearly visible. Another part was cut in half after applying the chemical-electrochemical treatment of Hirtisation®. All supports were able to be removed and the (internal) surface of the part was levelled and shiny. Fig. 2 shows the results compared to the untreated parts. The treated part is ready for use.

In conclusion there is no need to apply special tricks of the trade to achieve support-free printing of metals. There are industrially feasible finishing techniques that can completely remove internal support structures and powder residues and level the internal (channel) surfaces. Even curved, widening, or narrowing channel structures can be treated. However, as with any post-processing in an industrial environment, matching printing method to the final surface treatment is crucial for efficient and reliable part production. This allows the industrial production of complex parts to be automated and meets the requirements of mass automotive production, for example.

For more information:

Wolfgang Hansal - RENA Technologies  
Wolfgang.Hansal@rena.com

Article from: *Futurities* Year 19 n.3 Autumn 2022



# Simulation and integration of a DED repair pipeline into the machine tool control environment

by **Daniele Calsolaro, Livio Airaudi**  
EnginSoft

The terms "3D printing" or "Additive Manufacturing" (AM) refer to the creation of solid three-dimensional objects from a digital file by depositing successive layers of a material until the object is created. Each deposited layer can be viewed as a narrow cross-section of the final object. There are several types of material deposition process, such as powder bed fusion, binder jetting, material extrusion, material jetting, vat polymerization, and direct energy deposition.

Directed energy deposition (DED), more commonly called metal DED, is an AM technology related to metals, in which a metal in powder or wire form is melted using a high-density energy source and is simultaneously deposited locally to form the object in question.

DED technology can be used to repair existing components or to manufacture large new components. While it can be used to manufacture parts from scratch, the technology is mostly used in industry to repair large costly components like turbine blades or propellers that have been

damaged during use. As a result of the benefits accruing from its use, including cost and scrap reduction, shorter repair times, and minimization of inventories, and the related substantial environmental benefits, this technology is rapidly gaining in importance.

The EU EIT Manufacturing's OScaR project, which lasted from January to December 2022, was a collaborative undertaking to define a technological solution for repairing metal components using DED AM. Industrial manufacturers require an automated or semi-automated solution that enables them

to mount a part that has a partially unknown shape on a machine, measure the relevant part of its surface in 3D, and automatically generate an AM repair program to return the part to the desired shape.

### The OScaR project

A typical DED machine consists of a multi-axis instrument with a nozzle that deposits molten material onto the work surface – a base or component – that has been firmly clamped. The metallic material is fed to the nozzle as a powder or wire. This material is melted during deposition by a concentrated heat source – usually a laser electron beam or plasma arc.

In principle all weldable metals such as titanium and its alloys, Inconel, tungsten, stainless steel, and aluminium can be 3D printed with DED. The size of the wire used typically ranges from 1–3mm in diameter, while the powder particle sizes are similar to those used in powder metallurgy processes, i.e. between 50 and 150 microns.

Obviously, such a process generates temperatures with very high thermal gradients that can lead to significant overheating, deformation, and accumulation of residual stresses during the layer deposition phase; the deformation effects can be so great that they can affect the proper functioning of the technology and cause fracture or breaking.

Therefore, it is extremely important to be able to accurately predict, specifically by using finite element simulation, the effects of DED printing related to deposition, with the aim of optimizing the printing process in terms of time and to reduce the residual stress.

End users need an automated or semi-automated solution to mount a part with a partially unknown shape onto a machine, measure the relevant part of its surface in 3D, and automatically generate a repair program to restore it to the desired shape. The generated part must be automatically analysed to ensure inline quality control. Furthermore, since the repair process does not allow for failures, the use of a simulation tool is mandatory to pre-assess the results that can be obtained.

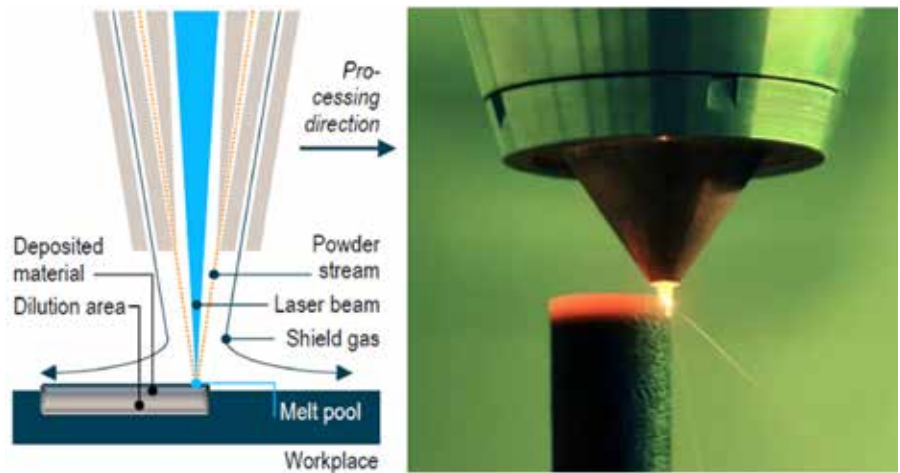

Fig. 1. Direct energy deposition (DED).

In many modern manufacturing environments, in-situ reconstruction of a damaged or faulty part's geometry is a highly desired function in the production pipeline, for example, damaged parts can be repaired/reworked to extend their life cycle. However, working on a damaged part requires applying the preferred remanufacturing or repair technology to a surface with a partly unknown shape.

Parts, especially those prefabricated externally, that have to move through multiple machines during production, also have this requirement for repair or remanufacture. Many industries would benefit from the ability to easily modify multi-process parts and repair damaged parts, but lack an established technology to 1) easily work on existing parts that have a far from nominal geometry, and 2) automatically generate an AM-DED repair toolpath for a damaged segment. Furthermore, quality control of the generated part must be performed entirely off-machine, requiring additional production time.

The OScaR (Optical SCAN-and-Repair solution for machine tools) project, co-funded by the EU's EIT Manufacturing, focused on the use of DED technology; in particular, the project's ultimate goal was to define a technological solution to repair metal components. OScaR enables the repair of complex metal parts for high quality applications using an AM-DED machine, in-situ 3D scanning, DED simulation and toolpath generation to achieve the next level of flexible manufacturing.

The project's most important impacts on the manufacture-and-repair industry worldwide are to enable:

- Environmentally sustainable production
- Lower energy consumption
- Reduced consumption of raw materials
- Reduced engineering time through automation
- Inline quality control of processed parts

### Simulating the DED repair process

EnginSoft's role was to develop a suitable simulation method and configuration to virtually replicate the DED process for repair applications, smoothing the path for new potential customers. The model to simulate the DED repair process is based on Ansys Additive Suite and enables the effects of the repair process on the reference part to be predicted and optimized. The Ansys DED simulation module imports a scanned baseline geometry and an externally generated G-Code. The main materials and process configurations relevant to the use cases are entered into the simulation parameters. The final simulation of the deposition process and its thermo-mechanical deformation was developed and tested on two principal use cases, which included validation of the results against real measurements.

Ansys Additive Suite is a powerful collection of tools from Ansys specifically for additive manufacturing simulation. Workbench Additive is one of the tools designed for use within



Fig 2. A-frame test case.

the Workbench platform and Mechanical application. The DED Process Simulation functionality in Workbench Additive is implemented as an ACT extension that must be loaded into Workbench. The objective of DED Process Simulation in Workbench Additive is to predict temperature-induced deformations and stresses in the various components on a macroscopic level during the production phase to prevent failures, while simultaneously providing trend data to enable improvements during the design phase of the additive process, including the orientation of the parts and their build order.

To simulate the DED manufacturing process, the analysis must follow the actual printing process as it is deposited and solidifies, so-called “track-by-weld” solidification. In this type of simulation, the thermal analysis and structural physics (stress and distortion) tend to be decoupled which allows the full thermal process to be simulated prior to the structural simulation. In a DED process simulation, the model evolves over time with elements being added during the process.

To begin, the full initial part is meshed using Cartesian or tetrahedral elements and then a “birth and death” technique is applied, which allows the sequential activation of element clusters to simulate the progression of the print job (where the term “cluster” defines a part of the weld path). In addition, the associated boundary conditions for each stage also develop as thermal convection surfaces. The build phase is complete when all the elements have been activated (brought to life).

Analysis times and time steps are controlled by the process parameters and are not known in advance; these aspects are verified internally during the simulation phase. The DED process requires a very detailed level of simulation using real weld lines and an abstraction known as element grouping.

This grouping is used to sub-divide the weld lines into smaller portions of mesh, called clusters, to which the thermal conditions are sequentially applied at each time step. Each cluster is thus a portion of a weld line that is created sequentially by activating that section through the birth-and-death technique and assigning to each newly activated piece the thermal conditions resulting from the thermal simulation performed on the previous piece.

The project involved an initial configuration phase using an example case (A-frame) after which the optimized method was applied to repair a turbine blade.

Simulation setup is guided by a wizard to ensure that all the necessary steps are followed to discretize the model and for the subsequent simulation. In particular, the wizard guides the user through the following steps:

- **Import Geometry:** defining the bodies to be printed;
- **Mesh Creation** (a hexahedral mesh is recommended): the DED Process does not require a strictly layered mesh of identical layer heights, but the weld trace must be represented in the mesh. A slightly coarser mesh is acceptable for the base plate because it simply

serves as a heat sink and fixed support in the simulation. Mesh types to consider include Cartesian, tetrahedral, and sweep meshes. A hexagonal (i.e. Cartesian) mesh should be preferred to a tetrahedral mesh if manual clustering is to be used because some tetrahedra may be excluded from element clusters for some geometries. We also recommend using linear rather than quadratic elements;

- **Clustering:** it is possible to create a cluster manually or to use a G-Code file, as in our case. The cluster volume (in mm<sup>3</sup>) is used to control the cluster size and therefore has a direct influence on the simulation time. This value determines how many elements are activated per loading step; the time for this loading step is then determined by volume/deposition rate. A smaller cluster volume tends to give a more accurate result. Depending on the overall size of the build geometry, this value should be determined by balancing the computing effort with the desired accuracy. Set the cluster volume according to the total volume of your part;
- **Material assignment:** in this window, you can assign the material to be printed and the basic components;
- **Define build settings:** in this step the user defines the machine and process settings and conditions, grouped according to three categories:
  - Machine Settings: The process parameters, which vary for each DED machine and according to the material used in the deposition process;
  - Material Deposition Rate: The feed rate of the molten material, in mm<sup>3</sup>/sec. This value can be determined by multiplying layer thickness (mm) x weld width (mm) x deposition speed (mm/sec); and
  - Build Conditions: The settings for the environment in the build chamber that surrounds the part during printing, including the preheating temperature;
- **Boundary conditions:** in this last step the user defines the constraints of the

model in detail and, more specifically, the bottom of the base is fixed to the ground;

- **Generate clusters:** before generating the clusters, the position of the G-code can be checked using the “Show path” option in the multifunction bar (green line for laser on, blue line for laser off).

### The two DED case studies

Following the setup described above, the transient thermal simulation was performed for the two case studies. Typical significant results are temperatures in the transient thermal solution, and displacements and equivalent stresses in the static structural solution.

The results obtained in terms of temperatures and equivalent Von Mises stress for the “A Frame” case study are shown in Fig. 3; the temperature and residual strain values were compared with the actual results obtained by one of the partners, SUPSI, using Prima

Additive’s DED machine, thus validating the Ansys results.

The full procedure was then repeated on an Inconel718 blade (the second case study) in order to verify that the method would work for an industrial case. In fact, this second structure is a perfect example of a major potential application for this method.

### Conclusions

The solution for repairing complex metal parts was developed, tested, and validated as part of the OScaR project. This complete part-repair method combines an AM-DED (directed energy deposition) machine, in-situ 3D scanning, DED simulation and toolpath generation to achieve the next level of flexible manufacturing.

The simulation tool pre-assesses the results that can be obtained by using additive manufacturing processes in the repair pipeline to get the part right the first time.

In summary, OScaR automates metal part repair through an advanced inspection and toolpath generation platform. The advantages for manufacturers and users are:

- An enormous reduction in the engineering time required to develop such repair strategies;
- The ability to repair a wider range of complex parts;
- Increased ease of repair compared to manufacturing parts from scratch; and
- Consequently, cost reduction throughout the production chain.

The results achieved are important for society because of:

- Environmentally friendly production (several large parts were repaired instead of replaced, as is currently common practice);
- Reduced energy consumption;
- In-line quality control of the processed parts.

In addition, the OScaR project

- Supported the development of a dedicated ecosystem for new services and value chains;
- Created a robust solution to enable the provision of high-quality manufacturing services for research and consultancy
- Enabled increased competitiveness.

### Acknowledgements

The OScaR project was co-funded by the 2022 EIT Manufacturing Call for Proposals for “Flexible production systems for competitive manufacturing”. We would like to thank all project partners (Prima Additive, SUPSI, inspire, AIDIMME, POZZO, and EnginSoft) for their cooperation and contribution to the success of the project.

For more information:

Daniele Calsolaro – EnginSoft  
d.calsolaro@enginsoft.com

This article will also be published in  
*Futurities* Year 20 n.3 Autumn 2023

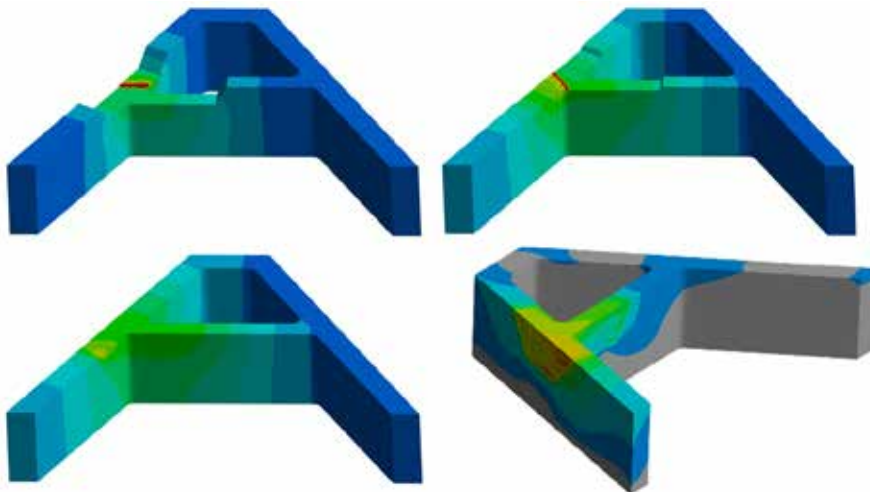

Fig 2. A-frame test case.

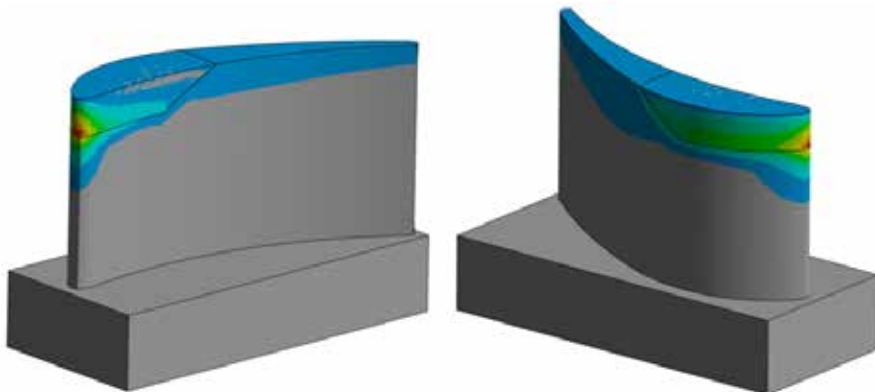

Fig. 4. Simulation and results of the DED repair process applied to the tip of a turbine blade.



## Soft shaping of hard metals

by Michael Kitzmantel, Kunal Mandal, Christian Pfeifer, Christopher Wallis, Erich Neubauer  
RHP Technology

The desire for 3D printed shapes is growing strongly in the cemented carbide (WC-Co and other hard metals) space, as in other sectors. These composites of ceramic phase tungsten carbide (WC) and a metallic binder (Co in our case) have excellent physical properties and are used in many applications requiring wear resistance and tribological properties.

There are three main applications for 3D printed cemented carbides according to their specific properties in the field of composites ranging from nano-grained microstructures to coarse carbides using nickel or cobalt or other metal binders.

### Application Areas

#### Cutting tools and inserts

Cutting applications require high hardness, extreme toughness, and specific, customized microstructures. The increasing performance and durability of products in this area also requires full density, i.e. no or only low porosity in the bulk material. From an additive manufacturing perspective, this could be called the highest class of perfection.

#### Protection and wear elements

Wear resistance is a key property for such applications, but hardness while important does not have to be at the highest values. The same is true for toughness. On the other hand, high geometric complexity and



Fig. 1. WC-Co parts printed from granules by indirect 3D technology material extrusion additive manufacturing.

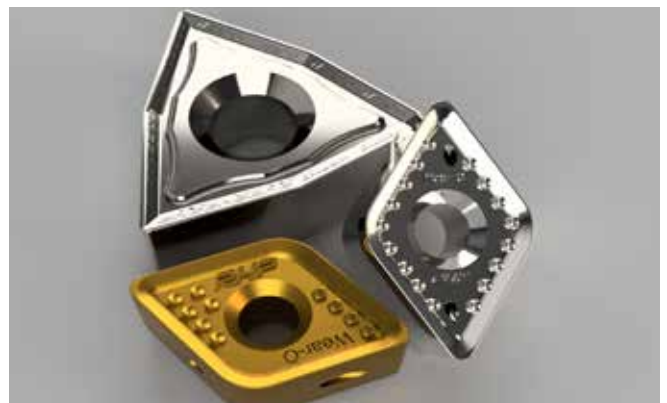

Fig. 2. Geometries of cutting tools that can be realized with 3D shaping technologies.





Fig. 3. 3D printed and sintered miniature cathedrals.

high precision are essential. Examples of this class of applications are nozzles for filament printers, waterjet cutting tubes, or sliding elements in moving joints.

### Jewellery and watch making

The main tribological requirements in this area are scratch resistance, followed by medium hardness, and defect size (porosity) below optical visibility. The parts must also withstand daily use and look beautiful. When we talk about 3D printing, this industry demands individualized features, spectacular surface topologies and novel haptic experiences.

It is in these application fields that additive manufacturing can play its most valuable cards – and particularly for very hard materials that are difficult to machine, AM technology offers unbeatable advantages.

### Injection moulding v. additive manufacturing

For small metal parts, ceramic parts and also cemented carbides, injection moulding technology holds a great advantage in producing the same part in high volumes. With its high level of automation, large production batches compensate for the high price of essential moulding tools and show high commercial competitiveness. This is not easily achieved by additive manufacturing.

However, both these technology classes produce so called 'green' parts that need to be sintered (heated to remove polymers and grow them into solid metal, ceramic, or metal-ceramic parts). When demand grows for new developments, small series, or deviating geometries, injection moulding requires significant investment, and this is where additive manufacturing comes in. AM offers rapid prototyping realization by maintaining this indirect manufacturing process (including the sintering step) rendering design changes easily feasible without increasing the cost of each iteration. A great benefit for industry!

In the following case study we show two technologies for processing cemented carbides by 3D printing: MEAM (material extrusion additive manufacturing, using granules or filaments) for parts with simpler geometries or very low-cost applications, and metal lithography for parts requiring high precision and surface quality.

MEAM technology already sustains comparison with injection moulded parts,



Fig. 4. Geometries of cutting tools that can be realized by 3D shaping of MEAM.

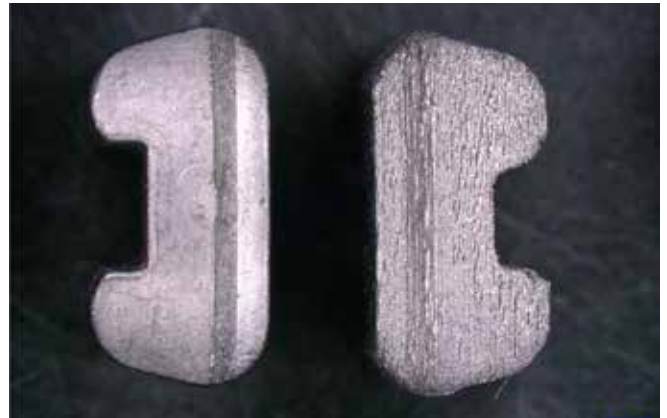

Fig. 5. Injection-moulded sintered hard metal part (left); MEAM 3D-printed and sintered hard metal part (right).

even if the surface quality is not comparable to that of typical injection moulding. Fig. 5 shows a microscopic image of a part manufactured by these two technologies.

### Material extrusion AM (MEAM)

This is an amazing technology that uses filaments, granules or pellets as its feedstock. In our case study, the printer is filled with WC-Co particles at a loading of 50% by volume. Several printers on the market that typically process polymer filaments or granules can be used for this process of 3D shaping of compounds. However, when it comes to geometrical complexity, this technology has the potential to create hollow structures and internal supports without a connection to the outside. This is possible because no residual powder removal or material extraction is required – the interior can be manufactured hollow and remains so throughout the process chain. The metallographic microstructure of MEAM-produced cemented carbides shows typical sintered structures for this class of materials, and hardness and toughness are also confirmed



Fig. 6. Cross sections of cut sintered MEAM parts with hollow structures internally.

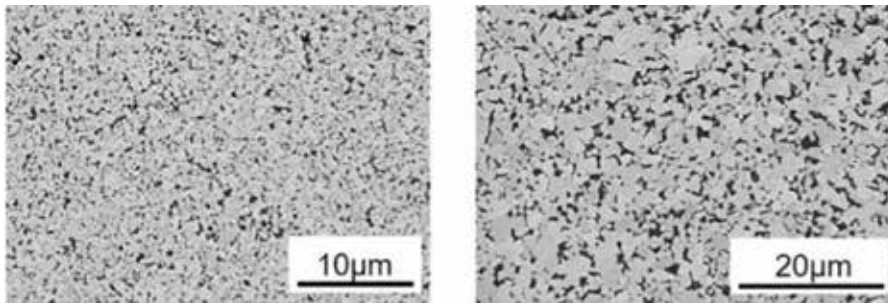

Fig. 7. MEAM microstructure of fine-grained (left) and coarse-grained (right) cemented carbides.

to be comparable. The main disadvantage is the occasional appearance of pores or cavities, which can result from incomplete path planning in the 3D printing process.

### Metal lithography

Compared to many other additive manufacturing technologies, stereolithography offers several major advantages for manufactured products: in addition to high geometric accuracy, excellent surface quality and aesthetics are also achievable. The technology under investigation is a VAT polymerization 3D printing technique in which the photosensitive binder that is part of the starting material solidifies when exposed to UV light. It supports a wide range of materials,

replacement of these source materials. The AM system in use at RHP-Technology features a highly viscous feedstock that eliminates the need for any support structures during printing – an unbeatable advantage for the production of complex and filigreed structures.

According to the above studies of our 3D printing system, and considering the advantages, this article illustrates that we were able to develop a carbide feedstock for lithographic 3D printing and continue successful parameter development for the printing process. As a result, complex parts for industrial applications were produced. In particular, an M6 bolt and nut made of WC-Co

and sintered. To obtain this final product, the production process consisted of feedstock preparation, 3D printing, post-processing and cleaning, two distinct types of thermal debinding to remove the binder, and sintering. A microstructural analysis was then performed. The first major challenge was to precisely mix the WC-Co powder with a photosensitive binder to develop the right amount of viscous feedstock to meet WC-Co printing requirements. The second was to find the printing parameters considering the light absorption of the carbide and the refractive index value. Carbide is certainly one of the most challenging materials to print. Finally, it was difficult to identify the sintering parameters to obtain a product with high relative density in which the Co distribution was uniform and homogeneous.

In our laboratory for photosensitive products (shown in Fig. 9) feedstock development takes place in a UV light-free atmosphere. Tungsten carbide (WC) with 10-20wt% of cobalt (Co) powder was homogeneously mixed with photosensitive binder. Since the binder is UV-sensitive, it must be protected at all times – during storage, handling, and processing.

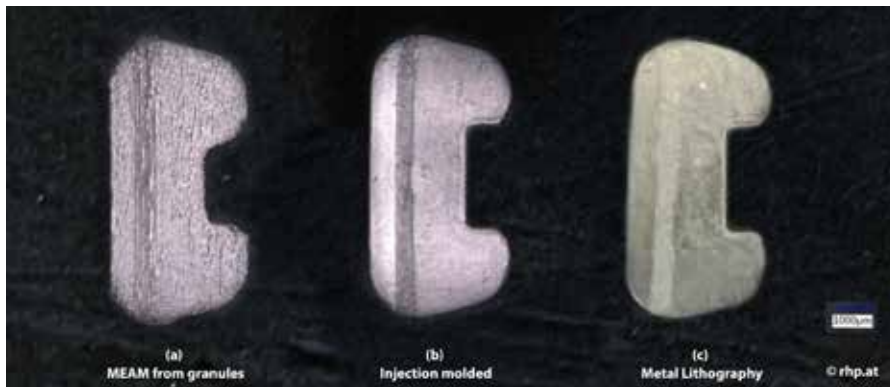
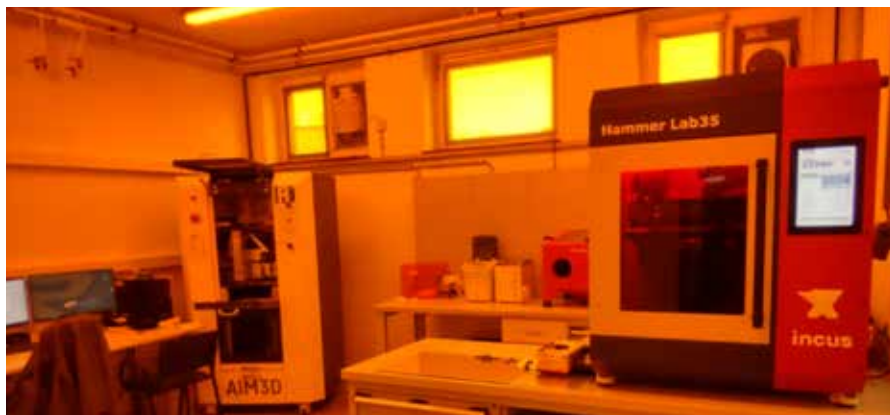

Fig. 8. HM part comparison of manufacturing routes.



and many systems allow for quick and easy composite material were designed, 3D printed,

## About RHP Technology

### Powder technology in Seibersdorf since 1996.

In October 2010, RHP-Technology was founded as a spin-off of the AIT (Austrian Institute of Technology). Since then, the company has transformed from a 4-person research group in the field of hot pressing to a world-renowned company for innovative powder technologies and intelligent material developments. Today, RHP is headquartered in Seibersdorf in Austria, with a second location at TFZ Wiener Neustadt, the national Austrian centre for innovative materials, space-related products, and advanced manufacturing. RHP is active in more than 100 customer and research projects, with its international team of 50 scientists and engineers strongly committed to innovation and going beyond the state of the art.



Fig. 10. Lithography-printed WC-Co M6 bolts and nuts.



Fig. 11. Sintered WC-Co M6 bolt and nut.

The WC-Co has high light absorption properties, which means that it becomes difficult to cure the binder for sharp and filigree structures during print exposure time, which affects the overall print quality. To overcome this, the binder had to be modified and the WC powder size selected accordingly. The final WC-Co powder content was about 50% by volume. Fig. 10 shows the M6 bolts and nuts fabricated using the lithography printing set up in our light-sensitive laboratory.

To achieve a high-density part, the green bodies were treated with several thermal steps in a hydrogen atmosphere, where the binder

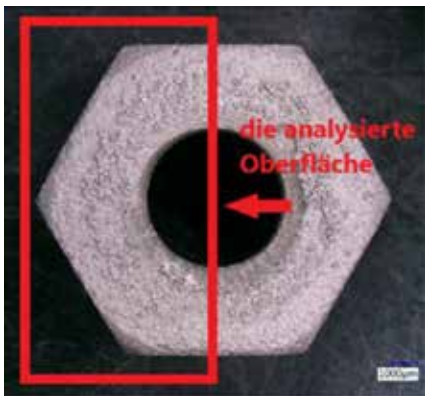

Fig. 12. The nut was cut in the area marked in red for the cross-section.

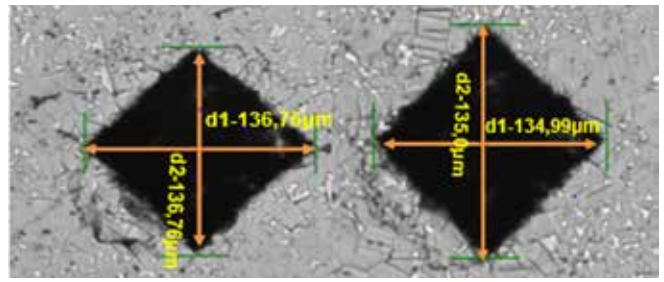

Fig. 14. Measuring points 4 and 5: 991HV10 and 1018HV10.

content is eliminated from the previously 'green' parts. In addition, a high-temperature sintering step was performed in a pressurized argon atmosphere (50bar) to obtain the final hard metal products with reduced porosity. To obtain general information on product density, we performed metallography and cross-sectional analysis of the M6 nut shown in Figs. 10 and 11. A hardness test measurement was also conducted to evaluate the WC-Co properties such as strength and wear resistance.

Fig. 13 shows the metallographic examination of the sintered samples after a process sequence of sectioning, mounting, grinding, polishing, and optical microscopy, specifically the WC and Co phases, with the black arrow indicating the Co phase (white area) and the red arrow indicating the WC phase (grey area). Resulting hardness values on the cross sections were measured between 896 (HV10) and 1018 (HV10).

Fig. 14 shows the fourth and fifth measuring points for Vickers hardness. Here we have determined 991 (HV10) and 1018 (HV10) for both measuring points. From all five measurement points we evaluated  $972.40 \pm 46.50$  (HV10). In summary, we demonstrated the development of WC-Co structures using both metal extrusion additive manufacturing (MEAM) and metal lithography techniques. The latter is a unique approach in the field of indirect additive manufacturing for extremely fine detail and high geometric resolution.

For more information:

Michael Kitzmantel - RHP-Technology  
m.ki@rhp.at

Article from: *Futurities* Year 19 n.3 Autumn 2022

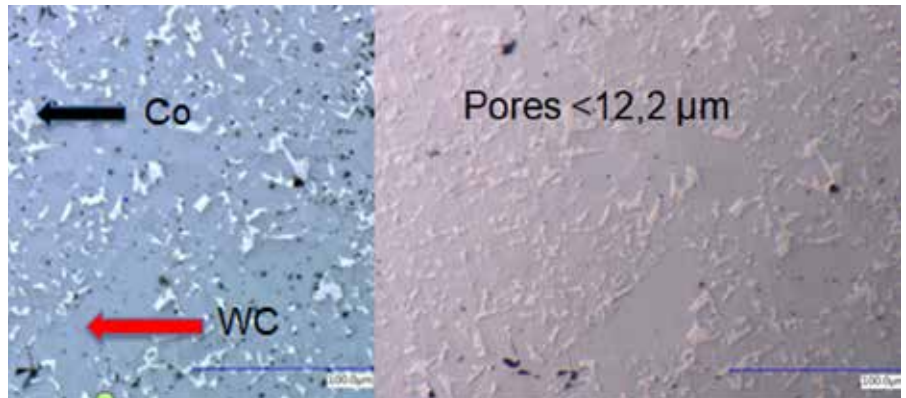

Fig. 13. Optical microscopy captured images in two different light settings for phase and pore analysis.



# Think big: XXL 3D printed titanium structures for space

by Johannes Niedermayer  
SBI

The industry's demand for unlimited geometric design is growing. Top wishes include optimizing the functionality and resource requirements and reducing the weight of final products. Additive manufacturing, also known as 3D printing, is one of the hottest game changers for these issues and has already conquered shop floors and R&D labs. There are a handful of technologies on the market focused on directed energy deposition (DED) to produce large-scale metal parts. One of these, Plasma Metal Deposition (PMD), stands out for its great economic potential and superior material properties.

## Plasma Metal Deposition (PMD)

SBI develops and manufactures plasma power sources and automation systems for welding tasks at its site in Ziersdorf in Austria. As a result, it began producing AM systems a few years ago. PMD (plasma metal deposition), the technology it offers, is a directed energy deposition process that uses a plasma arc as the heat source and materials in the form of wire, powder, or a combination of both. The PMD technology was developed in collaboration with RHP-Technology from Seibersdorf in Austria to give potential users of the process maximum flexibility in terms of raw material selection and application. Fig. 1 shows the diagram of the PMD process.

The constricted plasma arc forms a melt pool to which wire feedstock or coaxial powder is added laterally. The combination of both materials makes the process more flexible. Firstly, wire is widely and generally available in many materials. Secondly, the use of powders provides access to an ever wider range of materials – even hard metals or carbides that cannot be processed in wire form can be used. Thirdly, the combination of both materials makes it possible to print a bulk geometry with wire and give specific properties (e.g. corrosion and abrasion resistance) to the surface by printing the final layer with

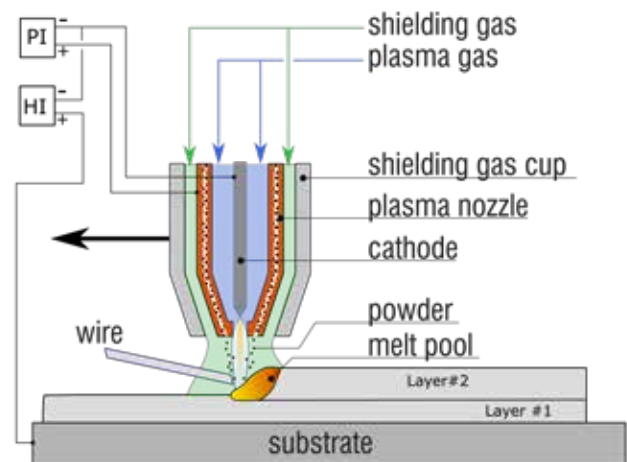

Fig. 1. Diagram of PMD technology.



Fig. 2. Printed bearing bracket made of Ti64 with partial machining.

powder. In general materials such as steels, aluminium, nickel-based alloys, and titanium can be processed with deposition rates up to 8kg/h. After printing, the part has an almost net-shaped geometry and in most cases postprocessing by milling, turning, etc. is required.

### M3DP, an industrial DED system

At SBI, the PMD process is integrated into the M3DP and M3DP-SL turnkey machine series. The metal 3D printer and its smaller brother, the SL (Scientific Line), make up SBI's portfolio of turnkey systems for additive manufacturing. Both systems work with G-code programming, which can be done either manually or with the CAPRICORN toolpath planning software. While manual G-Code programming is sufficient for simple mock-up walls for research studies, more complex structures require CAM-assisted toolpath planning and this is where CAPRICORN comes into play. With highly flexible strategy settings, the 3D model can be modified and prepared for planning (known as slicing in material extrusion 3D printing).

A subsequent simulation of the toolpath within the virtual machine model of the M3DP (or -SL) allows the user to check the toolpath, but also features safety functions such as collision detection.



Fig. 3. M3DP-SL system configuration.

When using titanium, the working chamber of both systems can be filled with argon gas to achieve oxygen concentrations of 50ppm and less. Within this protective atmosphere, the liquid and hot titanium is protected from harmful oxygen, moisture, and nitrogen which would influence the material properties towards higher tensile strength, but also higher brittleness, which is an undesirable property for most applications.

When it comes to printable part size, the M3DP offers a maximum working area of  $2.0 \times 0.6 \times 0.6$ m, while the M3DP-SL can process parts up to  $0.4 \times 0.4 \times 0.4$ m, both at a maximum deposition rate of 4kg/h for titanium and 8kg/h for steels.

### The Athena X-ray eye

The PMD process was initially trialled within the framework of the international R&D feasibility study ATHENA, initiated by ESA (European Space Agency). There, the process was used by RHP-Technology to print a total of six titanium demonstrators for an X-ray telescope. PMD demonstrated its potential to save materials ten times more effectively than conventional manufacturing i.e. milling. Whereas milling from a solid ingot would produce a total of 8.6t of titanium chips, PMD technology only produces 800kg.



Fig. 4. Machined demonstrator of a sensor bench made with PMD technology. Photo: RHP-Technology, © Ing. Robert Syrovatka

Together with RHP's R&D partners, Aerospace and Advanced Composites (AAC) and Forschungs- und Technologietransfer Gesellschaft (FOTEC) (both Austrian), the material properties of the demonstrators were intensively evaluated and analysed.

At its final size the sensor bench will be equipped with 750 mirror modules to form a high-performance X-Ray telescope for exploring the hottest and most energy intensive celestial bodies.

### Analysis and qualification of the 3D printed components

The additively manufactured segments were fully analysed for material properties and defects. Selected segments were subjected to non-destructive tests such as CT (computed tomography) scans to find any deviations, bonding problems, blowholes or similar. Critical defects could not be identified in the structure.

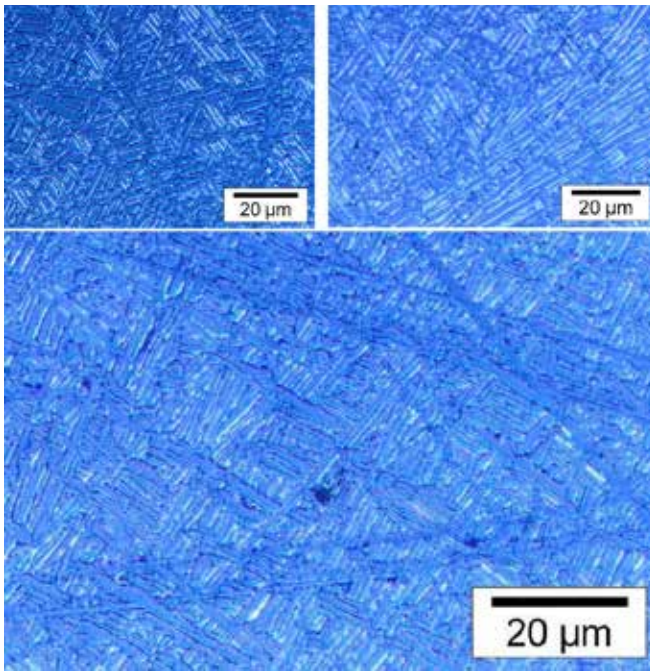

Fig. 5. Microstructure images based on sections from different areas of the additively manufactured component segments (in x, y, and z directions).

The program provided for the production of the segments via PMD powder and PMD wire and their comparison, so that comparative values are also available for both branches of this technology. Challenging locations such as nodes or welding gussets in the web guide were also examined in detail. At these points, the energy input or material deposition can differ significantly from wall or weave structures due to the process control. Also, with PMD components, one repeatedly sees the heat-affected zones of subsequent welding layers, which must be homogenized accordingly before a component can yield its maximum properties in use.

Standard	Material	Origin	Mechanical properties		
			UTS MPa	YS MPa	A%
ASTM B348	Grade 5	Billet	895-1000	828-910	10-18
ASTM B637	Grade 5-C	Casted	895	825	5
RHP	Ti-6Al-4V	PMD	895-930	825-865	10-13

Table: Evaluated mechanical properties of additively manufactured segments compared to characteristic values from ASTM standards.

Of course, thermal management requires special attention throughout the build process, especially with titanium materials where thermal conductivity is low. Therefore, appropriate time for heat dissipation must be planned for in the process control.

In addition to the plasma welding technology, the M3DP systems are equipped with a variety of sensors and cameras that enable continuous process control, monitoring, and regulation of the AM building process. Thus, material developments, prototypes, and series components can be produced on this system. Subsequent milling processes or heat treatments are undertaken via industry-standard equipment downstream so that the AM machine is not unnecessarily occupied with non-AM capacities.

For more information:

Michael Kitzmantel - RHP-Technology  
m.ki@rhp.at

Article from:

*Futurities* Year 19 n.3 Autumn 2022





## Lithography-based ceramic manufacturing: the industry standard for mass production with ceramic 3D printing

by **Norbert Gall**  
Lithoz

As the market-leading producer of innovative lithography-based ceramic manufacturing (LCM) technology, Lithoz has enabled a wide range of previously unimaginable applications in the industrial field, medicine and beyond. Steinbach, who are considered pioneers in the use of additive manufacturing (AM) for the mass production of high-performance technical ceramics, are just one example of a company who has used powerful Lithoz technology to drive their innovation further. This case study describes their journey to the successful and profitable manufacture of a new type of ceramic tube with complex geometries. Steinbach achieved an annual production rate of 12,000 units with comparable reject rates to conventional manufacturing technologies, and thus established itself as a leading ceramic AM service provider.

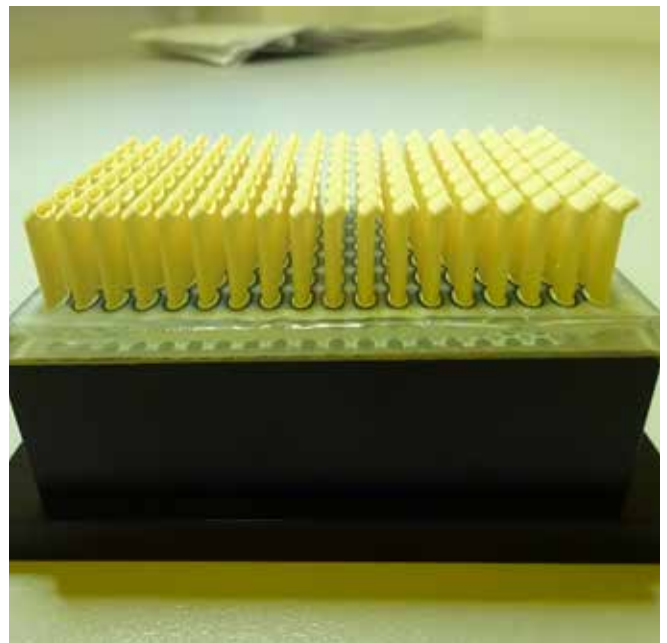

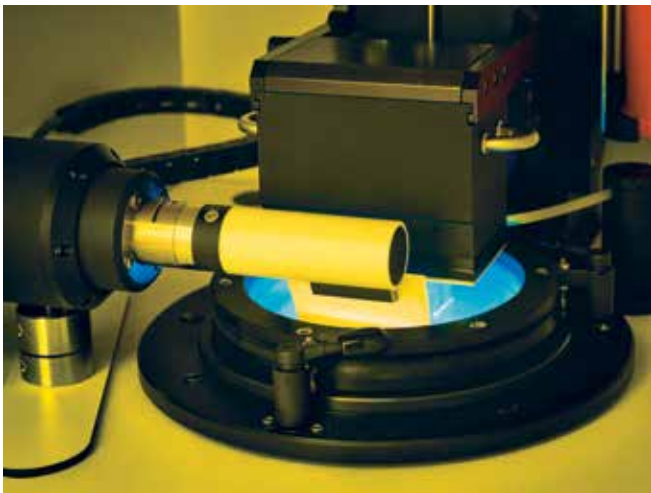

In the summer of 2017, Detmold, Germany-based Steinbach was requested by a renowned manufacturer of medical devices to produce a ceramic tube to be used as a guide element in a newly developed surgical instrument. After testing the first component printed with the Lithoz CeraFab 3D printer, the customer appointed Steinbach to develop and mass produce the part using the Lithoz LCM process. These complex tubes cannot be produced using traditional manufacturing processes and had to satisfy some very challenging requirements to meet the customer's business objectives.

The project had a specific target for the manufacturing costs and a tight deadline of six months to begin production. The obviously pioneering aspect was to use the established LCM ceramic 3D printing technology at an industrial scale.

Steinbach's specific objectives were to ensure the scalability of the production process and maintain consistently high part quality throughout.

### **Key features of the part and the requirements of the mass production project**

At the beginning of the project, the biggest challenges Steinbach faced were to meet some of the dimensional parameters defined in the production order. Producing a completely new tube geometry with a sharp bend and inner contours, minimal wall thicknesses of  $200\mu\text{m}$ , and perfectly smooth surfaces with roughness values of  $R_{\text{max}}=0.4$ , required all the innovative value of this new LCM solution. It was economically impossible to achieve the required narrow tolerance of  $+20\mu\text{m}$  in the outer geometry at a reproducibility of 12,000 pieces per year using traditional production techniques.

To meet the customer's economic expectations, Steinbach had to reliably transfer the superior material properties of the first parts produced with LCM technology into mass production. Implementation took place in three phases, focusing on the key criteria of productivity, process stability, quality assurance and economic efficiency.

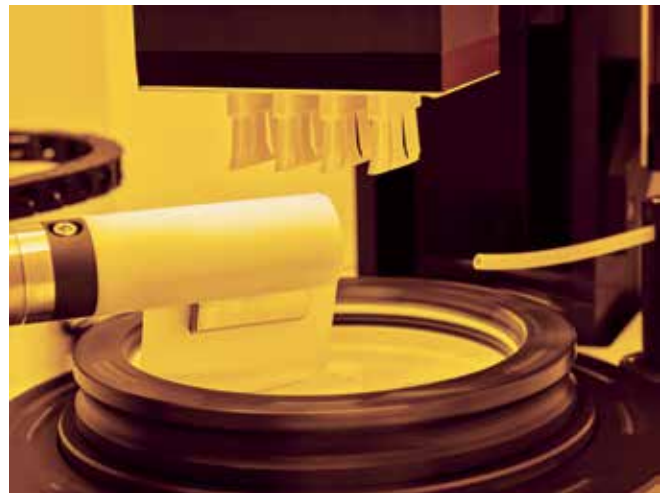

### **Phase 1 – Identifying a suitable part design for LCM technology**

Using consistent Design for Additive Manufacturing (DfAM) of the complex geometry, Steinbach collaborated closely with the customer to ensure the full functionality of the tubes throughout the mass production of thousands of components.

The functionality of the developed prototypes was thoroughly evaluated under close-to-series printing conditions to ensure that the component quality was ready for mass production from the first part. The product was validated at the customer's premises, with the printed part geometry obtaining the customer's approval.

### **Phase 2 – Scaling the process up for industrial mass production**

Subsequently, Steinbach's technical ceramics team focused on detailed process optimization to ensure the reproducibility of the part properties without any loss of quality during mass production. To achieve this, all the available potential of the LCM technology had to be fully explored and exploited. Software upgrades to







ensure pixel-precise component alignment were conducted in close cooperation with Lithoz. Systematic control measures were implemented to ensure consistent configuration of the manufacturing process.

After achieving solid production results, further measures were then implemented step by step to increase productivity – for example, by optimizing the part cleaning sequence and developing more efficient loading of the furnace to achieve better thermal processing.

## About Lithoz

Lithoz is the world and technology leader for high-performance ceramic materials and 3D printers. Founded in 2011, the company is committed to breaking the boundaries of ceramic production and supporting customers in expanding the manufacturing opportunities for the ceramic industry.

The company's export share is almost 100%, it has more than 125 employees, and has had a subsidiary in the USA since 2017. Lithoz has also been ISO 9001-2015 certified since 2016.

### Project at a glance:

<b>Task</b>	Production of high-performance ceramic tubes in batches of 12,000 per year.
<b>Material</b>	LithaLox (aluminium oxide)
<b>Solution</b>	Additive manufacturing-compatible design and implementation on a Lithoz CeraFab system.
<b>Benefits</b>	Economical mass production of ceramic tubes with geometries impossible to produce using traditional manufacturing processes.

The data obtained during the process optimization served as an analytical basis for quality assurance and as a statistical basis for decision-making in future projects. The customer's process audit concluded the final milestone of the second phase.

### Phase 3 – Ramping up to mass production with economic optimization

Six months after receiving the order, Steinbach delivered the first mass produced batch of components on schedule. By July 2019, the full production volume of 12,000 tubes per year was achieved in line with growing customer demand.

Each new adaptation was subject to customer approval of the resulting sample. By continuously increasing the efficiency of the process, as well as tailoring additional developments to the material, Steinbach's team repeatedly reduced manufacturing costs and minimized scrap to reach the specified target range.

### Successful completion of the project

In achieving economical production of 3D-printed ceramic components (as described above), Steinbach has taken a decisive step from business theory into business practice. By consistently optimizing the entire manufacturing process, the company successfully implemented mass production with LCM technology and reached the expected return on investment (ROI) across the entire value chain.

Through this project, Steinbach's team acquired full competence across the entire production process – from part design, through post-processing, to the finished sintered component. Other customers have also benefited from the proven knowledge gained, combined with Steinbach's efficient quality management and high-performance delivery. The success of this foundational project took Steinbach to a leading position in the AM mass production of high-performance technical ceramics for industrial and medical applications.

For more information:

Norbert Gall - Lithoz - [ngall@lithoz.com](mailto:ngall@lithoz.com)  
or contact: [info-tc@steinbach-ag.de](mailto:info-tc@steinbach-ag.de)  
[www.steinbach-ag.de](http://www.steinbach-ag.de)

Article from:

*Futurities* Year 19 n.3 Autumn 2022



SYNOPSIS®

## Heat exchanger optimization using additive manufacturing, simulation, CT inspection, and testing

by Kerim Genc  
Synopsis

Six industry leaders (nTopology, Ansys, EOS, Stress Engineering Services, North Star Imaging (NSI), and Synopsis) took on the challenge of developing a totally new and rapid design for a high-tech heat exchanger by leveraging the advanced capabilities of each of their companies.

The aims of the project were to improve the heat exchanger's energy efficiency and system performance while using less material in less space, and to combine design, simulation, CT (computed tomography) inspection, and testing to control quality in this expensive new product. The final model significantly reduced the pressure and the number of parts, and increased heat transfer.

### Design process with simulation

Most new heat exchanger applications have space constraints, with increasing thermal requirements driving the need for smaller and more efficient designs. However, there has been little innovation in common heat exchanger designs, which typically use inefficient tube

and shell geometries. Significant performance advantages can be achieved by using implicit geometry in the design of a heat exchanger with complex surfaces.

During the project, nTopology and Ansys collaborated to generate and simulate a new heat exchanger design. nTopology uses implicit geometry technology to create triply periodic minimal surface

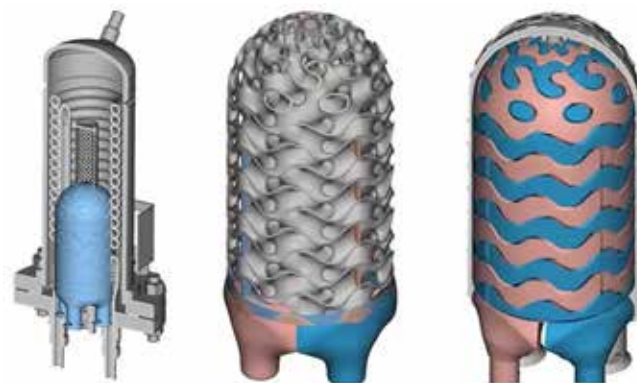

Fig. 1. The redesigned heat exchanger with TPMS geometry is much smaller than previous models.

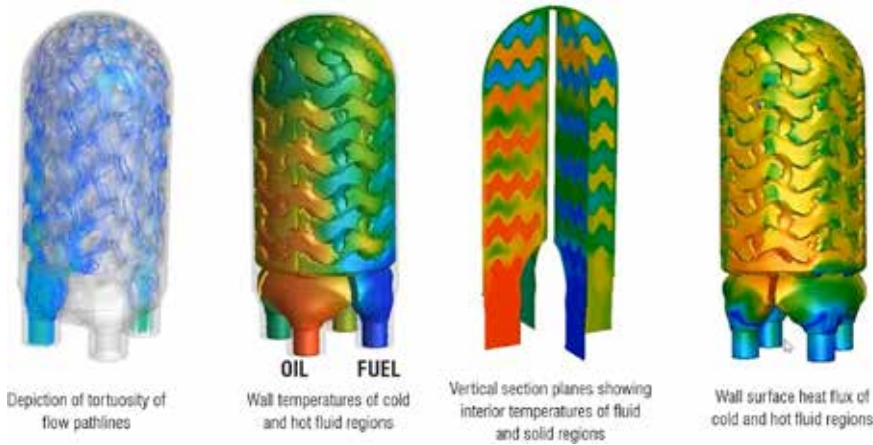

Fig. 2. Design validation results of the redesigned compact heat exchanger.

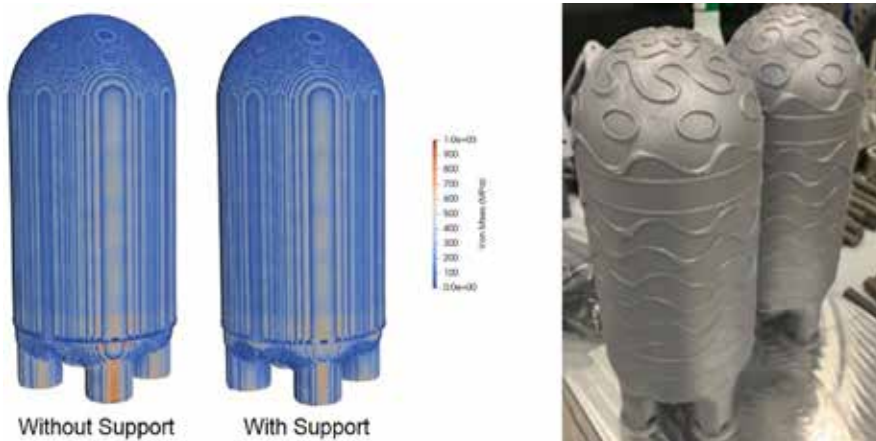

Fig. 3. Build process analysis (left), and the final part (right).

(TPMS) structures that are well suited to heat exchangers because of their smooth topology for flow dynamics. In addition, TPMS designs inherently isolate two regions (such as hot and cold), and their high strength-to-weight ratio makes them lightweight.

nTopology redesigned the heat exchanger using a TPMS geometry, which reduced the number of parts from 40 to one, resulting in an 81% decrease in total mass. Several designs were created and evaluated using Ansys software. First, Ansys Discovery Live was used to simulate fluid flow in real time for different design iterations. Engineers then compared the performance of a legacy heat exchanger design and the TPMS heat exchanger with Ansys Fluent CFD simulations. The results were impressive and included an 85% reduction in volume, an 11.7-fold increase in heat transfer per unit volume, and a 9.4-fold increase in heat transfer per unit mass.

Ansys optimized the build process from the design to reduce the risk of print effects, and

to minimize build time by using simulation tools to evaluate factors such as the best orientation, customized design for the support structure, and other inputs. The process simulation in the Ansys software also helped by predicting factors such as distortion, porosity, and microstructure, as well as providing the specific process parameters of the chosen EOS M290 metal 3D printer.

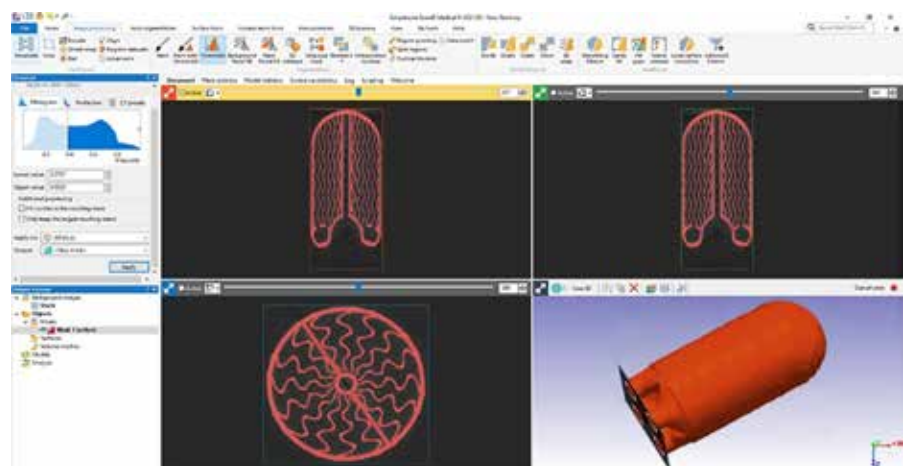

Fig. 4. The CT image data in Synopsys Simpleware software.

EOS conducted further preprocessing before setting up the build, and also performed remote monitoring during printing to ensure that no problems occurred. At the first attempt, an adequate print was achieved, taking around 62 hours for two parts, which were then put through post-processing steps including heat treatment to create a high-quality, 3D-printed component.

### CT scanning and image-based inspection

NSI CT scanned the part to create an image dataset that was imported into Synopsys Simpleware software to compare the heat exchanger's as-designed and as-built performance. In Simpleware software, the CT data was segmented to identify the solid and fluid domains, and to detect defects by visually inspecting the pores, holes, and cracks. Surface models (STL files) of the solid and fluid regions were then created and overlaid with the as-designed STL to analyze surface deviation. This approach makes it straightforward to identify differences between the designs as a result of manufacturing.

There was little deviation between the two designs – only some small areas at the base of the printed heat exchanger where printing had resulted in some rounding and left excess powder. Overall, however, the printed part was very true to nTopology's design. This image-based workflow may also be automated using machine learning to rapidly import, segment, and obtain the critical measurements for the user, reducing the risk of differences between operators.

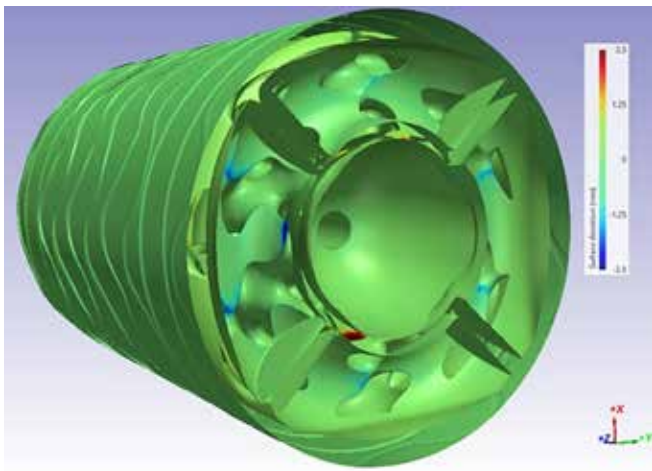

Fig. 5. Surface deviation analysis of the as-designed versus as-built parts in Synopsys Simpleware software.

### FE meshing and simulation

The next step in the workflow involved comparing the performance of the as-built part to the as-designed version. A multi-domain finite element (FE) mesh with conforming interfaces was generated in Simpleware software for import into Ansys software. Burst pressure was validated by subjecting the model to a large deformation plasticity analysis in Ansys, and material properties from the Ansys Additive Materials library were used to compare the scanned nTopology mesh with the original CAD mesh. Submodeling of the mesh allowed further performance analysis without requiring significant computing

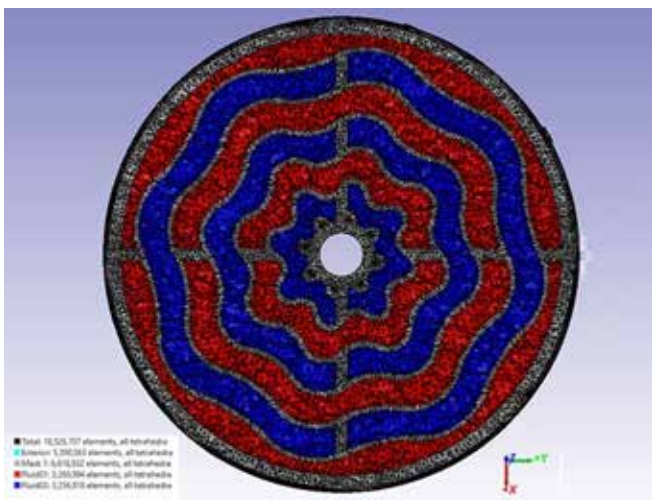

Fig. 6. Automatically generated multi-domain FE mesh in Synopsys Simpleware software.

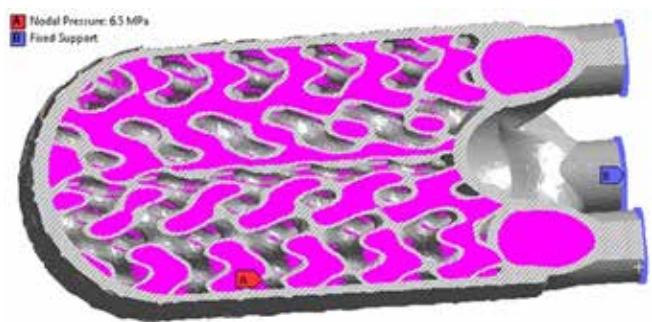

Fig. 7. Burst pressure test simulation.

resources. The simulations showed the as-built and as-designed performance to be similar, with only marginal improvements in deformation for the former, which may be a result of local thickening. To increase confidence in the heat exchanger's performance, Stress Engineering Services then conducted a range of large-scale physical tests.

### Full-scale testing

The redesigned component was installed in Stress Engineering Services' full-scale heat transfer flow test facility to measure the pressure drop and overall heat transfer coefficient. Hot and cold test fluid was passed through the heat exchanger to measure its performance. Thermal imaging was used to visualize the heat distribution in the heat exchanger during the tests, with results showing that the reduction in the hot fluid temperatures decreases as the flow rate increases.

After heat transfer flow testing, the heat exchanger was subjected to pressure testing. Pressure was increased gradually up to failure levels (loss of pressure). A sophisticated digital image correlation (DIC) system was used to measure the deformation in the heat exchanger during pressure testing.

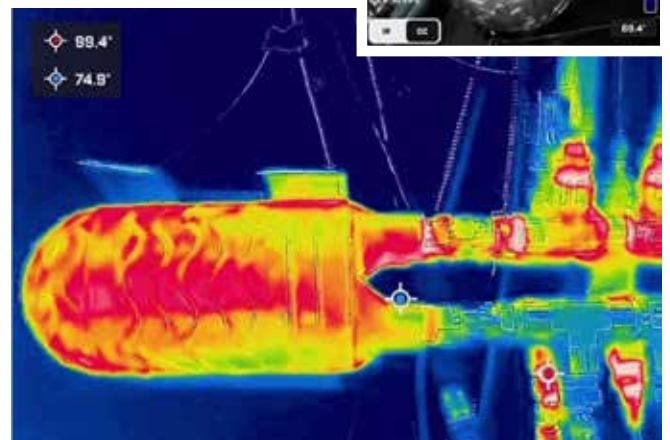

Fig. 8. Heat transfer flow testing with thermal image data.

## About SYNOPSISYS

Synopsys, Inc. (Nasdaq: SNPS) is the "Silicon to Software" partner for innovative companies developing the electronic products and software applications we rely on every day. As an S&P500 company, Synopsys has a long history of being a global leader in electronic design automation (EDA) and semiconductor IP and offers the industry's broadest portfolio of application security testing tools and services. Whether you're a system-on-chip (SoC) designer creating advanced semiconductors, or a software developer writing more secure, high-quality code, Synopsys has the solutions needed to deliver innovative products. Learn more at [www.synopsys.com](http://www.synopsys.com).

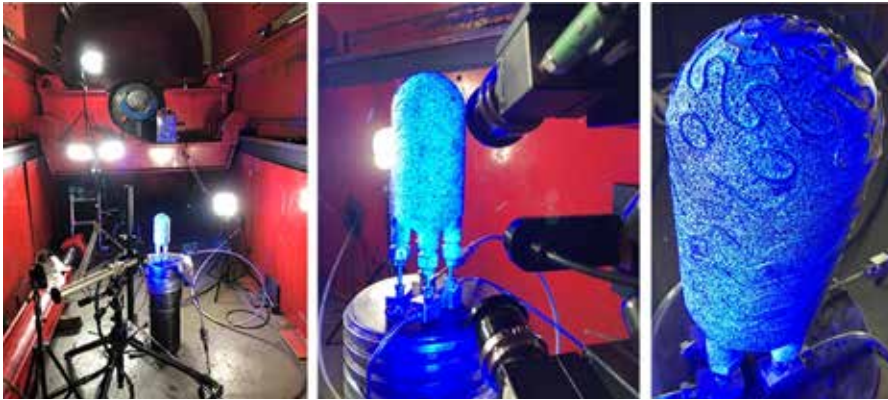

Fig. 9. Proof pressure test and pressure to failure (burst) test.

This system uses optical imaging to measure surface displacements and calculate strain. The entire visible surface of the test article could be measured and strains compared to FEA (finite element analysis) to refine the analytical model.

The performance of the 3D printed heat exchanger was also compared to a traditional, commercially available brass shell and tube heat exchanger and significantly outperformed it on flow rate, while exceeding the burst pressure requirement of 350psi more than 14-fold to demonstrate real-world suitability.

### Post-burst test CT scan

In order to establish a validation workflow, the prototype of the burst-tested heat exchanger was re-imaged to view the regions that had failed. Cracks were found in four regions near the base of the heat exchanger which corresponded to the areas that failed during the burst test. While the performance of the prototype heat exchanger far exceeded expectations, this post-test process helped to identify regions where the design could be further optimized.

### Results and conclusions

The use of TPMS for the redesign of the heat exchanger was successful at improving performance and reducing size to account for space limitations. Compared to legacy designs, the TPMS part achieved significant improvements, reducing volume by 85% and total mass by 81%, increasing heat transfer per unit volume 11.7-fold, heat transfer per unit mass 9.4-fold, and surface area per unit volume 7.9-fold. The TPMS design also reduced the pressure drop 9.1-fold on its hot side, and increased the

pressure drop 1.16-fold on its cold side. Reducing the number of parts from forty to one was also an important success for the project. With this workflow, each partner demonstrated how, by combining the latest technologies for design, inspection, additive manufacturing, and simulation, it is possible to redesign and validate the performance of crucial components. This approach has great potential to reduce material costs, accelerate processes from design to part, and increase efficiency in multiple areas.

### Acknowledgments

- Synopsys – Kerim Genc, Thomas Spirka, [synopsys.com/simpleware.html](http://synopsys.com/simpleware.html)
- Ansys – Sunil Acharya, Walter Schwarz, Mohammad Masoomi, Brent Stucker, [ansys.com](http://ansys.com)
- EOS – Jon Spragg, [eos.info/en](http://eos.info/en)
- North Star Imaging (NSI) – Brett Muehlhauser, [4nsi.com](http://4nsi.com)
- nTopology – Maiki Vlahinos, Ryan O'Hara (now Beehive Industries), [ntopology.com](http://ntopology.com)
- Stress Engineering Services – Matt Sanders, [stress.com](http://stress.com)

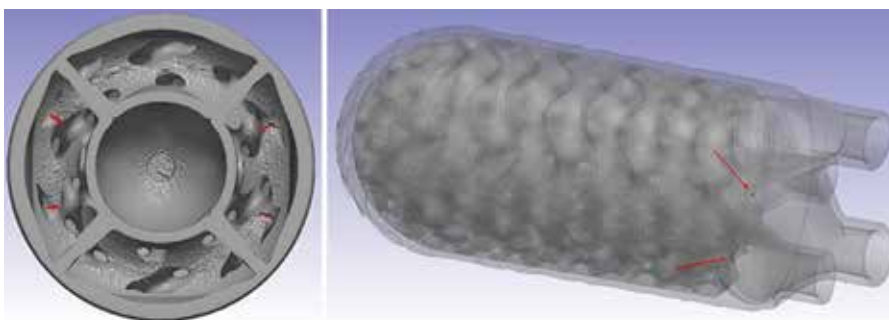
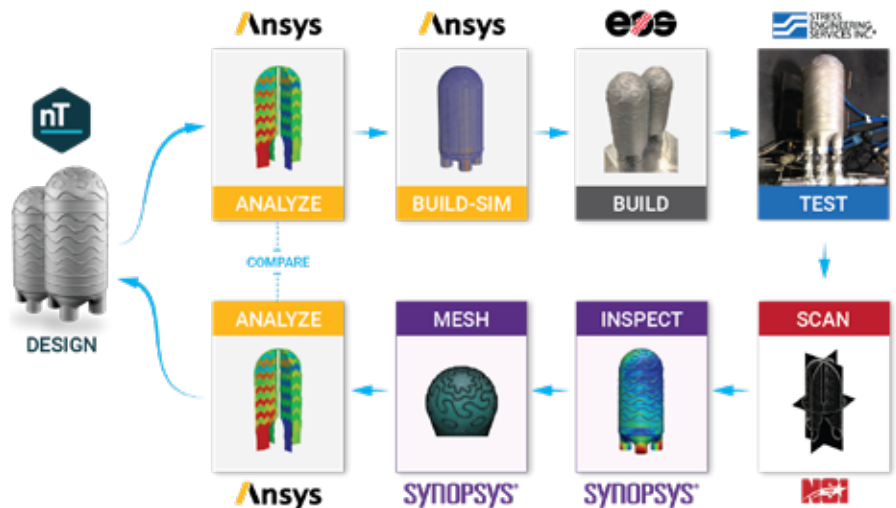

Fig. 10. Visualization of the heat exchanger after the burst test in Synopsys Simpleware software. Red areas highlight the regions of failure where cracks were found.

For more information:  
 Kerim Genc – Synopsys  
[kerim.genc@synopsys.com](mailto:kerim.genc@synopsys.com)

Article from:  
*Futurities* Year 19 n.3 Autumn 2022



A wrist cast applied to a patient.



## Using HPC tools to optimize 3D-printing of orthopaedic devices

by Janis Olins<sup>1</sup>, Karlis Muiznieks<sup>2</sup>, Janis Virbulis<sup>2</sup>, and Aleksandrs Gutcaits<sup>3</sup>

1. CastPrint - 2. University of Latvia - 3. Riga Technical University

The success story presented in this article was developed during the second tranche of the FF4EuroHPC project. The partners – CastPrint, the University of Latvia's Institute of Numerical Modelling, and Riga Technical University – teamed up to address a specific business challenge for an SME in the manufacturing sector and overcome it with the help of high-performance computing (HPC).

Plaster of Paris casts have been used to treat fractures for more than 150 years and are still considered standard practice in most cases. In recent years patient-centred healthcare and patient well-being

have become more important than just the basic healing, so the demand for improved solutions is constantly growing. While thermoplastic and fiberglass casts have been used for a considerable period, their effectiveness and value-added benefits are limited due to the time-consuming and material-intensive nature of their application.

### **The challenge: accelerating production times for 3D-printed orthopaedic devices**

The creation of 3D-printed medical devices, while many times faster than traditional casts, is nevertheless time consuming, and production capacity is limited by the number of manual operations required to be performed by designers. In addition, the 3D scanning used to create the casts consists

of millions of surface elements, which are time- and computer resource-intensive to render on PCs. In many cases this leads to software crashes and inevitable data loss, which in turn increases the time needed to get the medical devices to the patients.

### **The solution: optimizing the design process**

As patients demand better solutions, CastPrint has been providing bespoke 3D-printed medical devices to its institutional healthcare customers since 2016.

To address the challenges identified, the experiment partners chose to integrate parametric model optimization into the medical device design process. This involves using simulations to determine

the most efficient shape for the cast, which in turn reduces the amount of material required and shortens printing times.

HPC provides greater computing power and resources compared to desktop workstations. This enables faster and more effective simulations, the automation of certain aspects of the design process, which ultimately reduces the time spent on it.

CastPrint brings valuable medical expertise to the project, while the University of Latvia provides software development skills and Riga Technical University provides HPC expertise and resources.

### Business benefits and impact

The time to end-user was reduced by 25%. This was achieved through shorter design and printing times for custom 3D-printed medical devices, which lowers production costs by up to 15% and increases production capacity by 25%. Decreasing the time between scanning and printing opens opportunities in new markets. In addition, the shorter printing times and use of less material reduced costs, making CastPrint's casts more affordable for patients.

CastPrint casts are made of polylactic acid plastic, which is made from sugar cane and is therefore biodegradable. This cuts plastic usage by 25% which means less plastic waste is generated. Similarly, a 25% decrease in printing times means

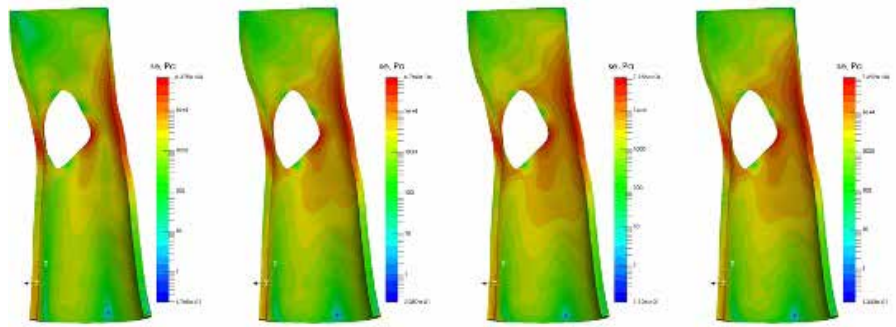

Fig. 1. Digital model of stress tests.

less electricity is used to print the device itself. By achieving the objectives of this experiment, the partners will contribute to reducing plastic waste and electricity consumption while improving the durability and wearability of the device.

### Benefits

- The introduction of an automated process using HPC shortens the number of hours spent on cast design by 20% while also minimising the risk of human error.
- Topological optimization decreases material usage in production by around 25%.
- Material optimization and shorter printing times reduce production time by 25%.
- CastPrint's production costs have been trimmed by up to 15% through reductions in printing hours, power consumption, and material usage.
- CastPrint's production capacity was increased by up to 25%.

- Initial calculations indicate an expected ROI of between 15% and 20%.

The success story presented in this article was developed during the first tranche of FF4EuroHPC Project. FF4EuroHPC supports the competitiveness of European SMEs by funding business-oriented experiments and promoting the uptake of advanced HPC technologies and services. The experiment is an end-user-relevant case study demonstrating the use of cloud-based HPC (high-performance computing) and its benefits to the value chain (from end-user to HPC-infrastructure provider) for addressing SME business challenges that require the use of HPC and complementary technologies such as HPDA (high performance data analytics) and AI (artificial intelligence). The successful conclusion of the experiment created a success story that can inspire the industrial community.



The FF4EuroHPC project has received funding from the European High Performance Computing Joint Undertaking (JU) under grant agreement No. 951745. The JU receives support from the European Union's Horizon 2020 research and innovation programme and from Germany, Italy, Slovenia, France, and Spain.

For more information:

Tina Crnigoj Marc - Arctur  
FF4EuroHPC Communication lead  
ff4eurohpc@hirs.de

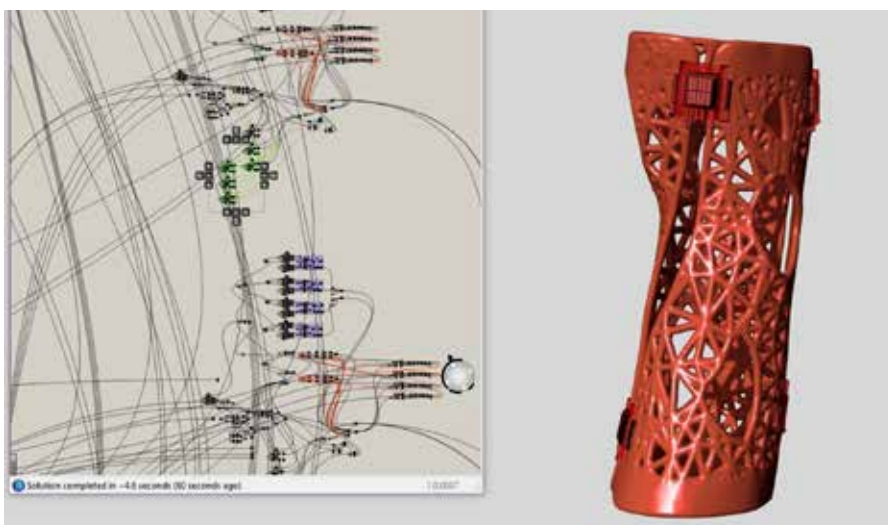

Fig. 2. Semi-automatic cast creation algorithm.

# DISTech's 3D printed metal parts revolutionize hydro-pulse impeller systems for electric boats using a process monitoring system developed in-house



Fig. 1. Hydro Impulse's impeller system mounted on an electric motor for boats.

by Christian Pfeifer<sup>1</sup>, Gernot Neuböck<sup>3</sup>, Nace Štruc<sup>2</sup>, Simon Malej<sup>4</sup>, Eva Smolak<sup>2</sup>, Wolfgang Kraschitzer<sup>1</sup>, Matej Balžaič<sup>4</sup>, Mátyás Tálás D.<sup>1</sup>

1. DISTech Group, Austria - 2. Stroka Produkt, Slovenia  
3. Hydro Impulse Systems, Austria - 4. Balmar, Slovenia

DISTech Disruptive Technologies, a pioneering additive manufacturing (AM) company, has made a significant breakthrough for the marine industry by successfully 3D printing metal parts for a hydro-pulse impeller system. The highly complex stern drives used in electric and hybrid boats have undergone a remarkable transformation thanks to the innovative capabilities of 3D printing technology.

This project was carried out in collaboration with Hydro Impulse Systems, an innovative technology developer based in Graz in Austria. Hydro Impulse Systems has developed a new type of propulsion system for watercraft, re-engineering a 200-year-old system to increase its efficiency from the 40–60% of current systems to a much higher level.

Until now, typical propeller systems have had to rely on conventional manufacturing methods to produce the intricate components they require to function. The limitations of traditional manufacturing have meant that achieving complex geometries and intricate designs was a significant challenge. This is where DISTech's metal 3D printing technology comes into play.

Printing these metal parts using additive manufacturing (AM) involves depositing metal powder onto a build platform in layers that are then

fused together using a high-powered laser. This layer-by-layer approach offers unprecedented design flexibility and enables the creation of complex geometries that were previously considered impossible using traditional manufacturing techniques.

The complex design of Hydro Impulse's impeller system posed a particular challenge. When DISTech CEO Wolfgang Kraschitzer and Hydro Impulse CEO Gernot Neuböck first discussed collaborative opportunities, they quickly realized that laser powder bed fusion (L-PBF) was the only technology that could produce the parts they needed.

Hydro Impulse Systems therefore turned to DISTech at an early stage of development. Together the companies developed the best geometry, taking into account the rules governing Design for Additive Manufacturing. Recognizing the immense potential of DISTech's 3D printed metal parts Hydro Impulse partnered with DISTech to integrate them into Hydro Impulse's highly complex impeller stern drives.

This collaboration resulted in a groundbreaking propulsion system that pushes the boundaries of performance and efficiency by enabling more complex parts to be made in a new way. The use of metal 3D printing technology in the manufacture of impeller system



Fig. 2. Side view of the impeller system.





Fig. 3. L-PBF process: 3D printing of the metal parts for Hydro Impulse.



Fig. 4. Metal 3D printing machine at DISTech.

parts is revolutionary, particularly in the electric boat sector. Electric and hybrid propulsion systems have become more important in recent years due to their environmental friendliness and the increasing demand for sustainable transportation options. By harnessing the power of additive manufacturing, DISTech has overcome the barriers of conventional manufacturing to create previously unattainable geometries and innovative, complex designs. The use of 3D printing has enabled Hydro Impulse Systems to produce highly customized and optimized stern drives with exceptional performance, reliability, and efficiency in low volumes for initial testing and early-stage development.

The 3D printed metal parts in the stern drives have not only helped to improve the drive's overall performance but have also significantly reduced production time and costs. Unlike traditional manufacturing methods that often require expensive tooling and extensive post-processing, 3D metal printing streamlines the production process, allowing for rapid prototyping and cost-effective manufacturing. After printing, only some minor post-processing of the surface and a little CNC machining of the functional surfaces is required.

However, it is well-known in the additive manufacturing industry that some imperfections can occasionally occur in 3D printed parts. Issues such as inconsistent powder coating of each layer; spatter particles due to the Marangoni effect; agglomeration of powders; and other effects can affect the quality of the final part. Imperfections are highly undesirable in a highly complex part such as an impeller that is stressed by enormous rotational forces, and cannot be allowed to occur in a certified part. Moreover, these imperfections can make it a challenge to balance the rotating parts. For this reason, DISTech partnered with two Slovenian companies: Balmar, an advanced aerospace manufacturing R&D

company from Celje; and Stroka produkt, an IT solution provider from Radlje ob Dravi. Together, the three companies developed an advanced process monitoring system that uses multiple sensors and machine data to generate a detailed history of the manufactured part.

The Digital Hybrid Additive Manufacturing (DIGI-H-AM) tool that they developed is a sophisticated monitoring system that encompasses all aspects of the powder bed fusion (PBF) process. Using state-of-the-art algorithms and IoT (Internet of things) technology, the tool collects real-time data from various sensors within the 3D printing machine, enabling detailed status monitoring throughout production. One of the key functions of the tool is the creation of a digital twin model. This virtual model mirrors the physical 3D printing process, logs all production data, and enables comprehensive analysis. By collecting and processing data from multiple sources, the digital twin plays a crucial role in identifying potential process errors, optimizing production parameters, and ensuring consistent part quality. The module predicts potential process failures in real time and can take precautions or react to these circumstances.

The digital tool is based on modular programming so that future upgrades are possible. There are also plans to use it for extremely complex manufacturing methods such as hybrid additive manufacturing using a part built with L-PBF that is then post-processed with a direct energy deposition (DED) machine. Through simulated IoT data visualizations, the digital tool provides users with a comprehensive overview of the full manufacturing process. This includes visualizations for process preparation, machine parameters, powder-quality data, and post-build data options for visual inspection, and both non-destructive and destructive testing.

By providing a holistic view of the additive manufacturing workflow, the digital tool enables operators to identify potential issues, optimize performance, and ensure compliance with certification requirements. The DIGI-H-AM tool has proven to be critical in streamlining the certification process for 3D printed parts. By logging all manufacturing data and



Fig. 5. Removing the support structure after 3D printing.

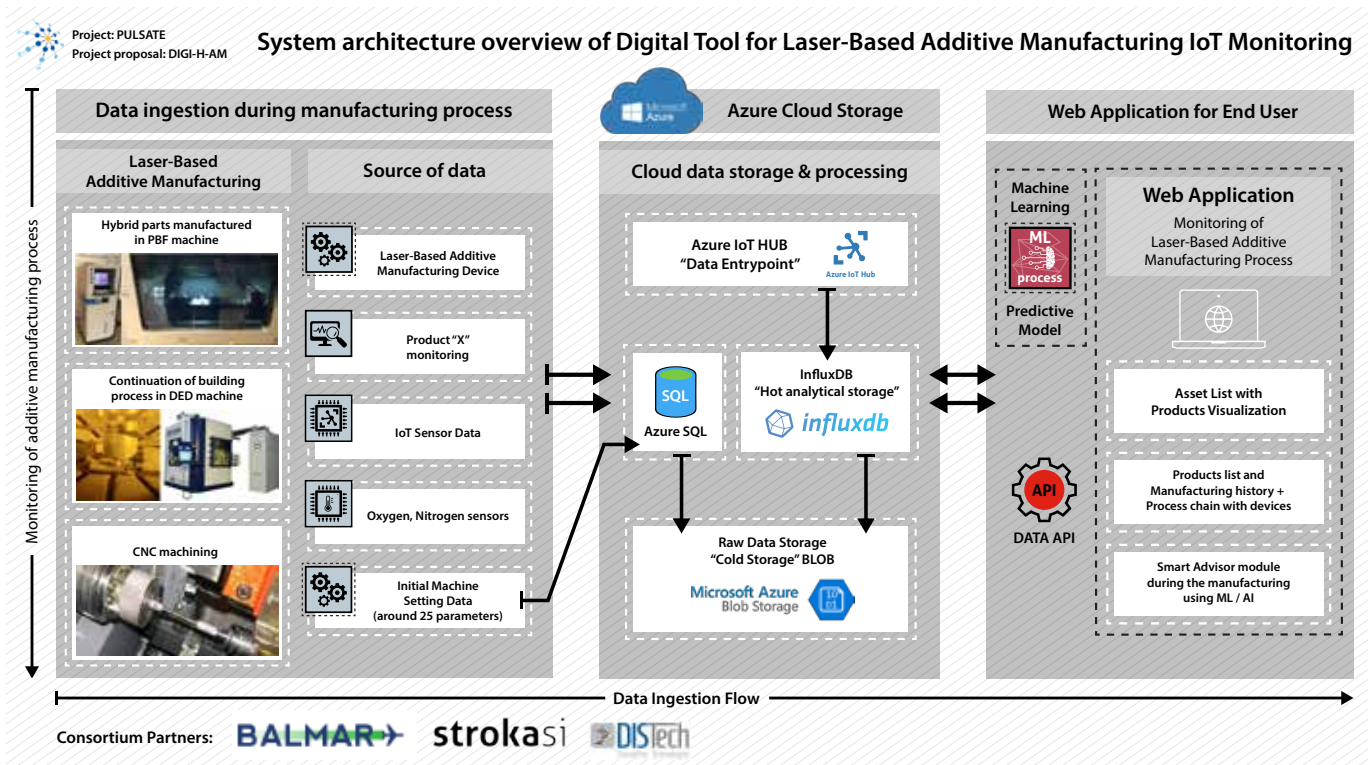

Fig. 6. Overview of the system architecture of the digital tool for IoT monitoring of L-PBF additive manufacturing.

providing real-time insights, the tool enables thorough documentation, traceability, and validation, which are essential for certification purposes. Furthermore, cloud-based storage of the collected data ensures accessibility and data integrity for future reference and analysis. Once a part has been manufactured, it has a complete production history, which is critical for several industries, including the marine sector.

Since the DIGI-H-AM digital tool drives advances in monitoring, analysis, and certification, it makes the potential of metal 3D printing to revolutionize manufacturing processes and

create highly complex geometries even more promising. "As the technology evolves, we can expect to see more breakthroughs in additive manufacturing that will shape the future of industrial production," says DISTech's Dr Christian Pfeifer. "The successful and flawless 3D printing for Hydro Impulse Systems represents a significant milestone for the marine industry and is a testament to the transformative power of additive manufacturing," comments Gernot Neuböck. With the remarkable success of this collaboration, the combination of 3D printing technology, manufacturing-data monitoring, and electric propulsion systems will revolutionize the marine industry and

pave the way for greener, more efficient, and sophisticated watercraft. In addition, the new monitoring system will be crucial for all future AM build jobs and the development team (DISTech, Balmar, and Stroka produkt) is considering a possible launch of a stand-alone version of the DIGI-H-AM system to enable users all over the world to use this system for their 3D printing machines.



This project received funding from the European Union's Horizon 2020 Research and Innovation Programme under Grant Agreement No. 951998. [www.pulsate.eu](http://www.pulsate.eu)



Fig. 8. Screenshot of the Digital Tool - Asset section for asset parameters, attachments, IoT data and manufacturing history.

For more information:  
Christian Pfeifer,  
DISTech Disruptive Technologies GmbH  
[christian.pfeifer@distech-group.com](mailto:christian.pfeifer@distech-group.com)

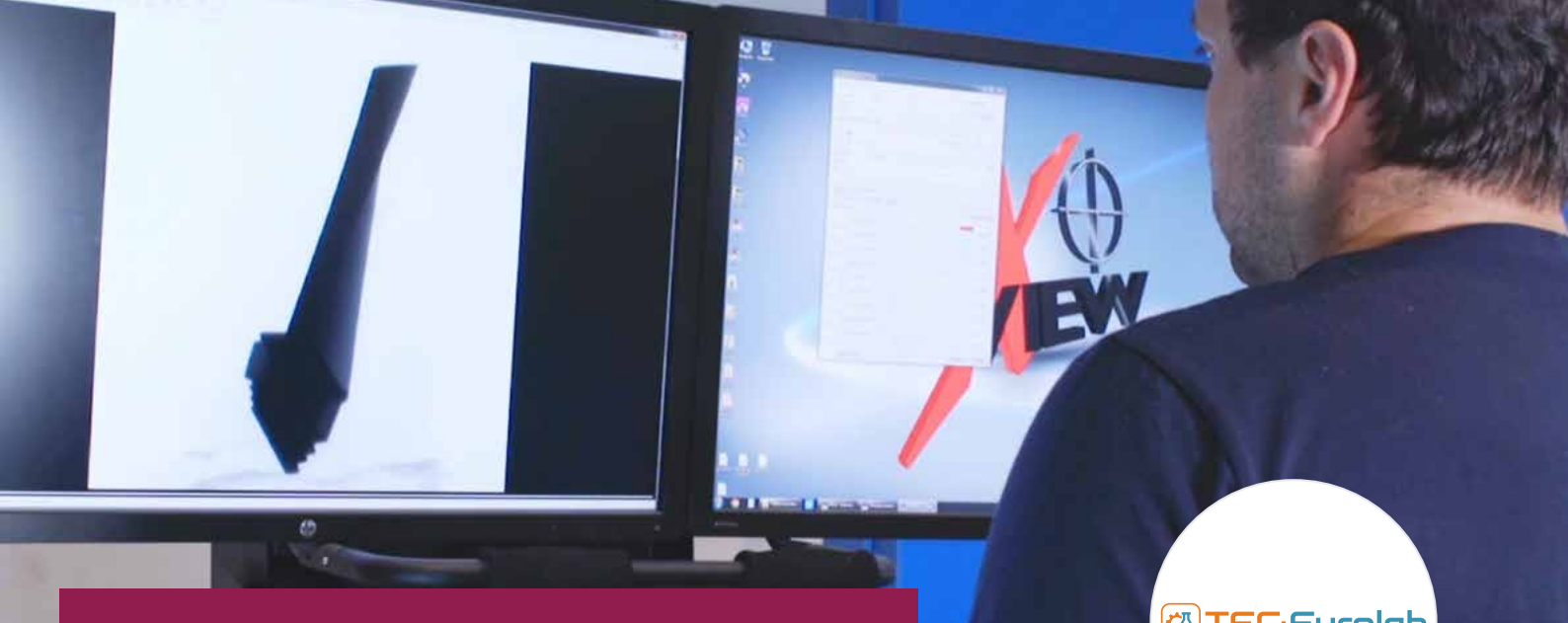

# Enhancing quality assurance in additive manufacturing: harnessing the power of industrial computed tomography

Revolutionizing non-destructive testing for AM components through comprehensive defect and dimensional analysis

by **Fabrizio Rosi, Fabio Esposito, Maria Francesca Silingardi**

TEC Eurolab

In recent years, additive manufacturing (AM) has revolutionized the field of manufacturing, enabling the production of components with high geometric complexity and functional sophistication. Like for subtractive manufacturing, ensuring the quality and structural integrity of these components is critical to their safe and effective use. The use of non-destructive testing (NDT) methods is crucial to verify the quality of AM parts, prior to their intended functional use, at all stages of the production process – from material feeding to optimization during production and from verification of surface properties to inspection during use.

In order to comprehensively evaluate the best approach for non-destructive testing of components in AM, certain peculiarities and limitations that currently characterize all components manufactured with these technologies need to be taken into consideration. Specifically:

- Components have fundamentally anisotropic mechanical properties, which makes characterization more complex from the perspectives of material and component control;
- Online monitoring methods are being developed to detect potential defects during component production, however they need to be validated using reliable and repeatable NDT techniques;

- There is still limited literature on the impact that defects, when present in an additively manufactured component, can have on the degradation of the component's functional performance;
- For each type of manufactured component, experimental campaigns are required to correlate microstructural properties with results from NDT; establish reference benchmarks; and determine the best inspection techniques to detect potential critical defects. Appropriate inputs related to component geometry, stress conditions, and material properties are required to determine the critical defect size;
- It turns out that the possible defects observed often appear to be non-repeatably distributed among different components of a series, making it more challenging to study the factors that led to the occurrence of the defect.

As is obvious, the non-destructive inspection of AM components has several critical issues and limitations. In parallel with the development of AM technologies, there has been significant progress in recent years in the field of industrial computed tomography, both in terms of its technological capabilities and its widespread acceptance.

Among all currently available NDT methods, this non-destructive diagnostic technique represents the best compromise in terms of ease of use, amount of information generated, and interpretability of results.

# Computerized tomography (CT) in industry: a brief overview

Computerized industrial tomography (CT) is an advanced method of non-destructive testing (NDT) widely used in industry to inspect the internal structure of objects without causing any damage.

Similar to medical CT scans, industrial CT uses X-rays to create detailed 3D images of the inside of the object including all defects and the internal and external geometry with micrometric precision and definition.

The dimensionally calibrated 3D volume generated allows quantitative measurements to be taken.

## How it works

Industrial CT works by rotating the object to be inspected while it is being scanned by an X-ray beam. X-rays pass through the object and are detected on the other side by a specialized sensor called a detector.

The detector records the intensity of the X-rays, which are influenced by the density and thickness of the material. A computer processes this data and reconstructs cross-sectional images, or "slices" of the internal structure of the object. These slices are then combined to generate a 3D image, which enables a thorough study of the object's interior.

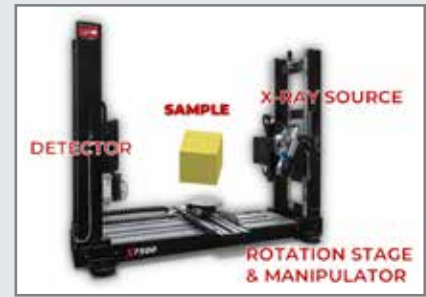

Fig. 1. Main elements of a tomographic system.

In Fig. 1, an x-ray tube acts as the source of the radiation that penetrates the object to be inspected; a high-resolution sensor, such as a flat-panel or linear detector, captures the x-rays passing through the object; the object is mounted on a rotating platform that manipulates the object and enables it to be scanned from multiple angles; a system of Cartesian axes is used to translate the x-ray images into the X, Y and Z directions; finally, software-based advanced computer algorithms process the raw data and reconstruct the 3D images into a complete volume of the inner and outer features.

The steady increase in the size of additive manufacturing systems and the adoption of higher-density metal alloys, such as copper and superalloys, have required a progressive strengthening of the power of the radiation sources used in tomographic systems in order to guarantee the quality of the reconstructed volume, detect any internal defects, and perform dimensional measurements.

In general, low voltage systems (240kV-450kV) are best suited to the analysis of low to medium density alloys and composite materials. For large, high-density alloy components, industrial tomography using a linear accelerator source (LINAC) is best for high-quality volumetric reconstruction (see Fig. 2).

CT system	Technical data	CT 2D slice	Reconstructed CT volume
 <p>NSI X5000</p>	<p>Source: 240kV-350W power output</p> <p>Max. resolution: 5µm</p>		
 <p>NSI X7500</p>	<p>Source: 450kV-1,500W power output</p> <p>Max. resolution: 70µm</p>		
 <p>D7 6MeV LINAC</p>	<p>Source: 6MeV</p> <p>Max. resolution: 140µm</p>		

Fig. 2. Example of tomographic scans performed on the same nickel-based superalloy component (turbine blade), analysed on each of TEC Eurolab's three tomographic systems.

Industrial computed tomography (iCT) provides a detailed three-dimensional view of the inside of manufactured components, revealing defects, porosity and imperfections that could compromise their functionality. This article will explore the applications and advantages of this diagnostic technique for inspecting components produced via additive manufacturing and will highlight its crucial role in ensuring the quality and safety of products manufactured this way.

iCT has become an important tool in the world of additive manufacturing, enabling comprehensive defect and dimensional analysis. CT scanning allows manufacturers to assess the integrity of printed parts without compromising their structure, which has revolutionized quality control processes and led to improved productivity and reliability across the AM industry. This is because iCT is the only NDT technique that allows complete inspection of an AM component, from defect to dimensional analysis.

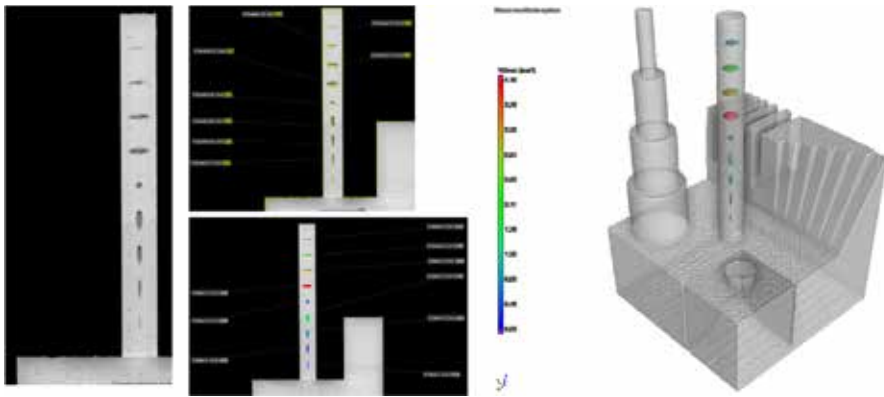

Fig. 1. Demonstrative component for defect analysis by computed tomography - example of a demonstration instrument made of AISI10Mg alloy and containing artificially created defects to demonstrate the ability to classify and dimensionally measure any defects present in an additive component.

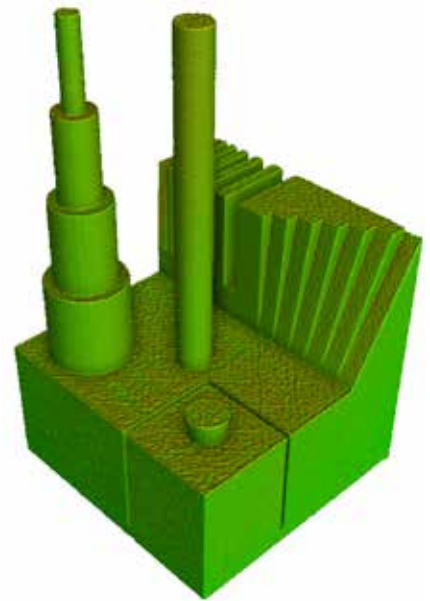

Fig. 3. Demonstrative component for defect analysis using computerized tomography - example of dimensional measurement of features in the same instrument as Fig. 1.

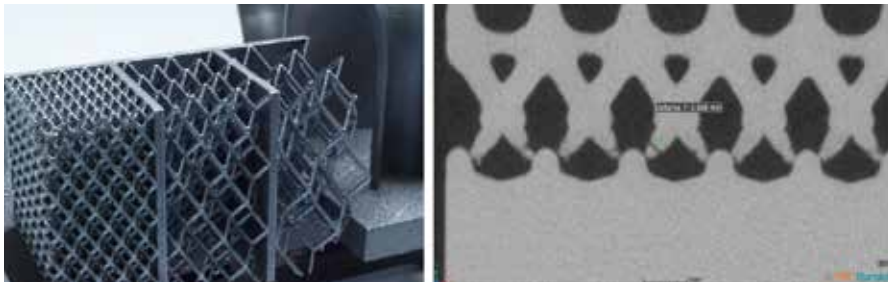

Fig. 2. Example of different types of lattice cells that can be manufactured using AM technologies (left) and a tomographic section of a lattice structure (right). Note the presence of cracks in the material at the junctions between bulk material and lattice cell sections.

## Defect analysis

Various defects can occur during the AM printing process including porosity, voids, cracks, and delamination. These defects can significantly affect the mechanical strength and overall performance of printed parts. CT scanning allows engineers to detect and characterize these defects non-destructively.

CT imaging provides high-resolution three-dimensional views of the internal structures of printed parts. By analysing the CT scans, engineers can accurately locate and assess the size, shape, and distribution of defects inside the 3D printed part (see Fig. 1).

This information is crucial to understanding the root causes of defects and making necessary adjustments to the AM process, as well as for optimizing printing parameters such as laser power, scan speed, and layer thickness. By identifying and correcting the specific errors that occur during the printing process, manufacturers can improve the quality of printed parts, reduce material waste, and increase overall productivity.

One possible application in which industrial tomography appears to be the only applicable non-destructive diagnostic method is the analysis of lattice structures (see Fig. 2). Lattice structures are lightweight, strong three-dimensional grids composed of interconnected hollow cells.

They reduce weight without compromising strength, enabling material and weight savings in industrial applications. Lattice structures have the further goals of reducing production costs and time while realizing highly complex geometries that would be impossible to achieve with traditional methods.

However, lattice structures present several challenges in terms of creating a representative sample for mechanical and material characterization, and in terms of inspecting these structures using NDT methods. With industrial tomography any defects in the structure can be accurately detected, allowing considerations to be made to make the subsequent analytical path more meaningful.

## Dimensional analysis

Dimensional accuracy is critical in AM because the printed parts must meet precise specifications and fit correctly into larger assemblies. Common dimensional deviations in additive manufacturing include warpage, shrinkage, and distortion. CT scanning helps identify these variations by comparing the scanned part with the original CAD model or design specifications. By quantifying dimensional deviations, engineers can make informed decisions about process adjustments. Here too, CT scanning provides a powerful dimensional analysis tool that allows engineers to non-destructively assess the dimensional accuracy of printed parts.

CT scanners capture high-resolution three-dimensional images of printed parts, enabling accurate measurement of both internal and external dimensions (see Fig. 3).

This feature is particularly useful for complex geometries that may be difficult to measure using conventional methods. By analysing the CT data, engineers can

assess the dimensional accuracy of printed parts and identify any deviations from the intended design.

### Virtual metrology

In addition to dimensional and defect analysis, CT scanning enables virtual metrology, eliminating the need for physical measurements. By extracting precise measurements from CT data, engineers can obtain accurate information on critical features such as hole diameters, wall thicknesses, and complex geometries.

The new ISO/ASTM 52902 standard provides guidelines for the qualification and calibration of AM machines, defining procedures and metrics to evaluate the performance and accuracy of AM systems and ensure consistency and reliability in the production of printed parts. TEC Eurolab has been studying this standard, and investigating its limitations. To do so, we designed and implemented a reference tool that includes the functionalities specified in the standard as well as others typical of AM technology.

Through this in-house project, we discovered, for example, that ISO/ASTM 52902 does not consider internal features, despite the fact that complex internal and external geometries are one of the main applications of additive manufacturing (see Fig. 4).

In addition to the possibilities offered by industrial tomography as a non-destructive inspection method, the generation of a

complete 3D volume of the component provides a range of information that can be used as input for simulation activities, thus providing a link to traditional non-destructive diagnosis and design.

Considering these further possibilities offered by industrial tomography, TEC Eurolab developed two application examples. These are:

#### 1) FEM simulation of real components with internal defects

This provides an economical and efficient approach to assessing the impact of defects on the performance and reliability of expensive components.

By accurately modelling the presence and characteristics of defects, engineers can simulate the component's behaviour under various operating conditions and assess the potential risks associated with such defects. This information enables informed decisions to be made regarding the acceptability of the component and the

need for further testing or remedial action. Ultimately, this application helps minimize waste and maximize the use of valuable components by providing a comprehensive assessment of their structural integrity and performance.

#### 2) Artificial intelligence for defect analysis

Defect analysis in industrial environments is often reliant on trained and certified operators. However, the subjective interpretations and time-consuming nature of manual analysis can introduce inconsistencies and delays in the assessment process. To address this challenge within TEC Eurolab, we developed an AI-based solution that improves the objectivity of defect analysis, democratizes the process, and promotes sustainability.

Our AI solution uses advanced algorithms and machine learning techniques to analyse CT scan data and identify defects with high accuracy. By automating the

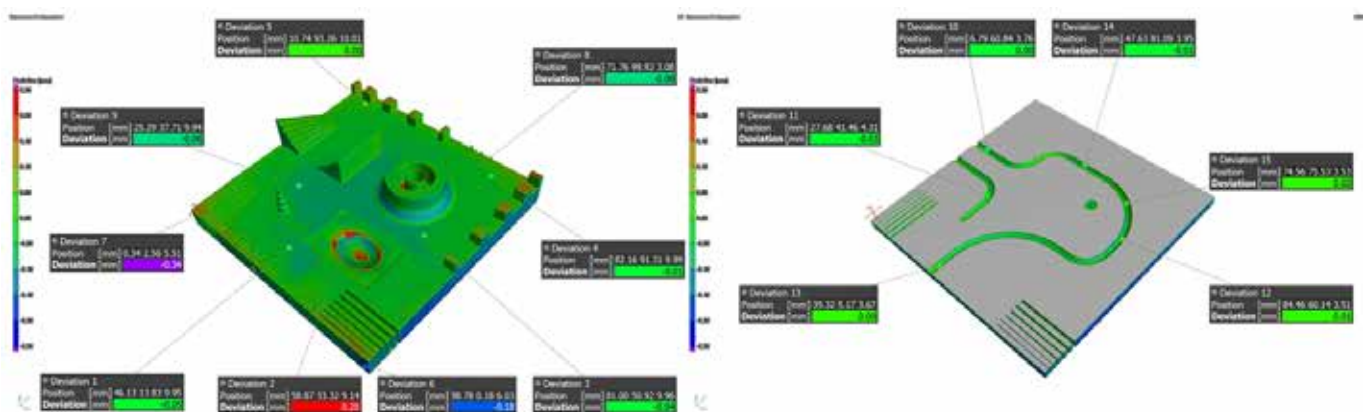
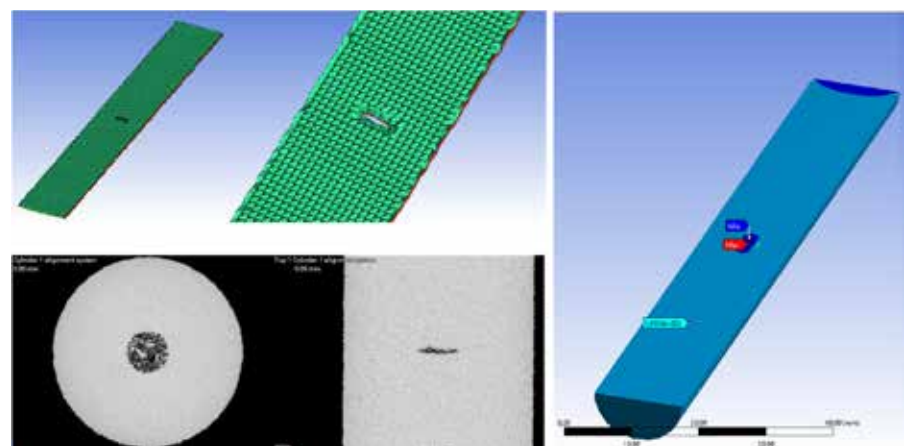

Fig. 4. Demonstrative component for defect analysis using computed tomography - example of an instrument for metrological verification. Note the realization of internal channels for dimensional verification of internal features that are difficult to detect with other NDT methods.

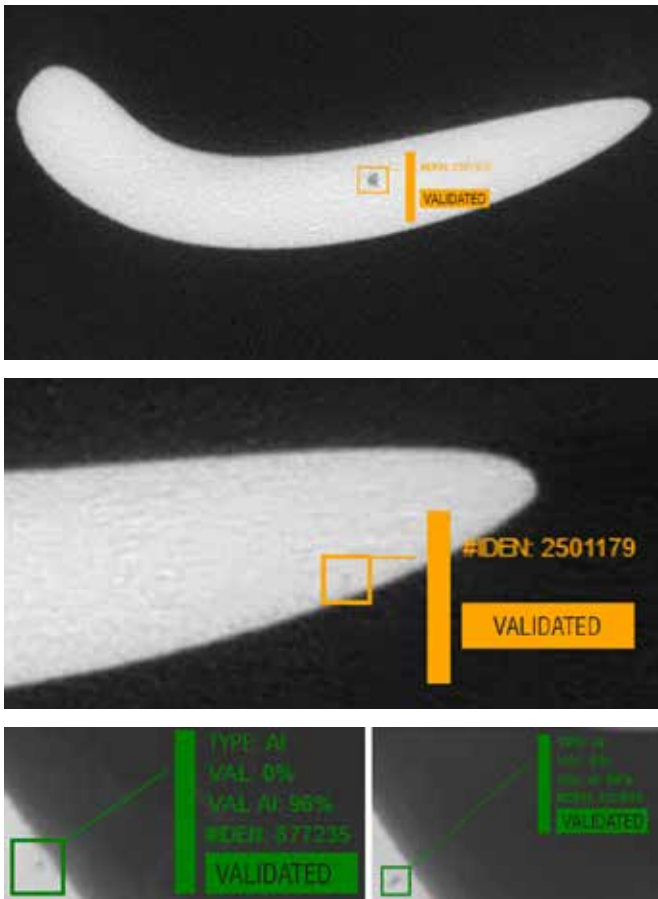

Fig. 5. Example of defect identification in component made of light alloy by additive manufacturing using artificial intelligence-based software

## About TEC Eurolab

TEC Eurolab: empowering manufacturing industries with quality assurance and innovation. For more than three decades, TEC Eurolab has been consolidating its position as a trusted third-party industrial laboratory. Our extensive experience ranges from materials analysis and non-destructive testing to training, and certification for industries as diverse as automotive, aerospace, energy, biomedical, food, and cultural heritage. Accredited for the rigorous UNI CEI EN ISO/IEC 17025:2018, 17024:2012, and 17065:2012 standards, we epitomize competence, independence, and unwavering objectivity. Furthermore, our prestigious NADCAP accreditation and UNI EN 9100:2018 certification illustrate our proficiency in the aerospace and defence sectors.

At TEC Eurolab, we specialize in meticulously evaluating and qualifying materials and processes to optimize product performance. Our bespoke support ensures that every component and product surpasses project requirements. With a team of skilled professionals and innovative technologies at our disposal, we instil unwavering certainty in product quality, empowering companies to make informed decisions with the utmost confidence. TEC Eurolab offers accessible expertise and state-of-the-art tools, and works closely with customers to transform results into practical solutions that elevate their products to unparalleled prominence.

analysis process, we minimize the potential for human bias and ensure consistent and reliable results.

This not only improves the objectivity of defect analysis, but also reduces the dependence on the expertise of the individual operator. Furthermore, our AI-based solution significantly accelerates the process of defect analysis. What used to take days with manual analysis can now be done in a fraction of the time. This efficiency enables faster decision-making and supports timely action to correct identified defects, ultimately improving productivity and reducing downtime.

## Conclusion

Industrial computed tomography (iCT) has emerged as a powerful and indispensable tool for non-destructive testing in additive manufacturing. This diagnostic technique addresses the unique challenges posed by AM components, enabling comprehensive defect and dimensional analysis. iCT excels in defect analysis for additive manufacturing components.

With high-resolution 3D visualizations, it accurately detects and characterizes defects like porosity, voids, cracks, and delamination. This information helps to understand root causes, thereby optimizing manufacturing, improving quality, reducing waste, and increasing productivity.

iCT is also particularly useful for analysing complex lattice structures, which are lightweight, robust three-dimensional lattices composed of interconnected hollow cells. Accurate detection of defects in these structures allows engineers to make informed decisions to ensure the integrity and functionality of the lattice components. iCT's dimensional analysis ability allows internal and external dimensions to be measured accurately, including complex geometries that are difficult for traditional methods. Engineers then compare scanned parts with CAD models to assess accuracy and make necessary manufacturing changes.

Furthermore, iCT enables virtual metrology by extracting precise measurements from CT data, providing accurate information on critical features such as hole diameters and wall thicknesses. This improves consistency, reliability, and quality control in the 3D printing of parts, increasing productivity.

For more information:  
Fabrizio Rosi - TEC Eurolab  
rosi@tec-eurolab.com



# How to increase the competitiveness of startups in the AM space: macro-economic development

by Vito Chinellato<sup>1</sup>, Alois Hotter<sup>2</sup>, Alexander Schmoekkel<sup>2</sup>

1. VC Consulting - 2. AM Ventures

In the recent past outsourcing – especially to low-income countries – was regarded as a cost-effective way to improve business competitiveness. More recently this trend is reversing with the focus shifting away from developing physical products and on to systems that meet users’ needs while reducing life-cycle costs and environmental impacts.

This changing landscape presents an important opportunity for additive manufacturing (AM) to support these trends and promote sustainability in the manufacturing sector. The move away from the traditional models of producing goods that are then transported around the world to a model that integrates products and services locally (known as reshoring) offers enormous potential for innovation and increased competitiveness.

The benefits of a re-shoring strategy were recently highlighted and reinforced by the White House’s “Additive Manufacturing Forward”

initiative, which aims to bring manufacturing capacity back to the USA and increase the resilience and competitiveness of American supply chains. The key benefits of reshoring are time-to-market, which increases competitiveness; direct manufacturing of parts, which ensures greater resilience; and high customization, which further increases competitiveness.

AM allows both time-to-market and the total cost over the entire product life cycle to be reduced. AM’s ability to manufacture highly customized parts directly from 3D CAD files can strengthen an end user’s competitive position while also being more environmentally efficient. Essentially, AM allows end users to streamline their supply chains by bringing manufacturing capabilities closer to the point of use, thereby breaking the traditional logistics cycle.

AM is a disruptive technology that significantly lowers the former manufacturing and logistics barriers and opens up a field of possibilities. By integrating tools, fixtures, and assembly lines, parts



can be manufactured directly from a 3D CAD file without the need for highly structured production equipment. Moreover, if no digital file format is available, the original part can be digitized using 3D scanning.

In high-value manufacturing, the role of customization in delivering new products and services is fundamental. AM's capabilities mean that it is therefore considered to be an important advanced manufacturing process, specifically because it enables the production of high-value, complex and customized parts. Examples from the biomedical field are the creation of patient-specific implants, or the mass customization of dental crowns and bridges.

**The state of the industry**

By 2020, 40 years after the first commercial machines were developed, the AM sector had grown to an industry with a turnover of around €14 billion and an annual growth rate of 22%. The sector remains extremely dynamic, with more than 200 players competing to develop new hardware, software, and materials.

Rapid innovation is leading to significant improvements in the performance of AM technologies. The latest generations of machines overcome many of their predecessors' perceived limitations by, for example, enabling the production of overhanging parts without the need for elaborate support structures, or creating stronger parts by controlling the orientation of fibre reinforcements using magnetic fields. Furthermore, the range of materials available for use in AM systems is expanding and includes high-strength aluminium alloys and medical-grade polymers.

AM systems are also becoming faster and faster. New systems based on selective laser sintering (SLS) use up to one million laser diodes to accelerate part production, and improvements in software and post-processing technologies further streamline the end-to-end work from concept to finished product.

In many industries, AM has become widely accepted as the fastest and most cost-effective way to produce working prototypes during product development and testing. AM technologies are also used in a growing number of "indirect" applications, including tooling, spare parts, and fixtures. Faster machines, better materials, and

smarter software are helping to make AM a realistic solution for many real-world production applications. As the technical hurdles fall, the onus is on end users to improve their understanding of these rapidly evolving technologies by developing the skills, processes, and business models to take full advantage of the benefits of AM, which will ensure that it becomes a driving force. For instance, end users should design new parts for production by AM based first and foremost on business or performance reasons and only thereafter should the optimized version be printed. There is no point in merely copying traditionally produced parts because there is no gain of additional value.

To explore these opportunities yet keep their investments manageable, companies should create and collaborate with a suitable ecosystem of partners that allows them to access the capacity, expertise, and capital needed to experiment with different approaches and technologies.

**The role for AM start-ups**

Start-ups have a crucial role to play in moving AM to the next level of maturity. There is a growing need for innovative start-ups that will further revolutionize the industry. Whether with new materials, techniques, or software, there is a lot of potential for disruption in this space.

As innovators, start-ups are in the continuum disruption by combining existing products/services in more attractive forms and developing completely new ones with new business models. It is widely recognized that startups have different traits compared to large companies, due to the fact that they operate in extremely dynamic environments characterized by a particularly high degree of uncertainty.

Due to their lack of capital, time and knowledge resources, these entrepreneurs must therefore manage their young companies efficiently in social, financial, and environmental terms. On the other hand, their small size and flat hierarchies enable them to be extremely innovative, fast, and adaptable in a constantly changing environment. One of the many challenges for start-ups is to develop the key business processes and procedures on the supply side that ultimately enable the market launch of their product/service. Especially in the context of increasing globalization and digitalization of industry it is no longer

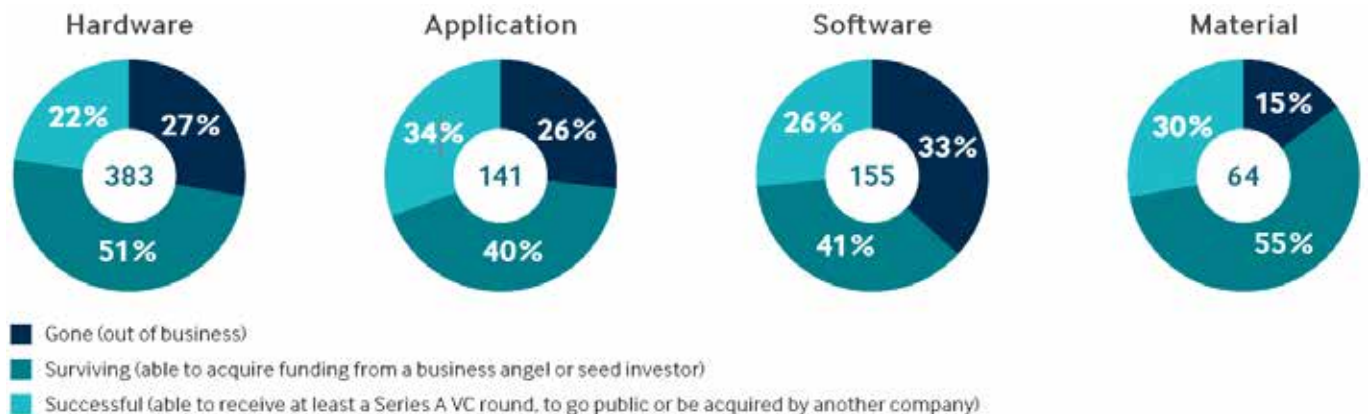

Fig. 1. Survival and success rate per technical field. Source – AM Ventures' White paper. Image courtesy of AM Ventures.

sufficient to simply develop a superior physical product. It seems equally important to have an efficient and effective operating model that can deliver a sustainable product solution which maximizes perceived customer benefits while minimizing the required resources.

Product supply chain processes also create value by being responsive, fast, and flexible, enabling high product quality. Start-ups therefore need to design customer-centric business operations models across the supply chain that makes sustainable use of materials, information, and money and can outperform the often larger competition. To achieve such a supply chain design, several key business processes need to be defined and prioritized, and certain strategic decisions made prior to launching a product. This trend is placing a lot of strain on traditional manufacturing tools and channels.

Historically, the start-up ecosystem has been one of the hottest topics in the investment industry. Financial experts focus on the difficulty of starting a new company and succeeding. AM Ventures, a 3D printing investor based in Germany, therefore undertook research to better understand the key factors governing start-up success in the AM industry and published the results in a white paper which provides a comprehensive overview of how AM start-ups are perceived today. Using AM Ventures' proprietary database of over 2,500 startups in the industrial 3D printing space, various regression models were applied to test whether the characteristics attributed by AM Ventures to ultimate investment success are statistically significant.

The company notes that there are three key elements that are directly linked to a startup's success: its team's human capital; patent protection; and the targeting of B2B markets.

Apart from the positive influence of human capital, the company's research confirm that patent protection has a significantly positive impact on the probability of success. This result is in line with previous studies showing that in complex product industries such as biotechnology, semiconductors, or information technology, patents are positively associated both with the probability of raising funds and with the amount of venture capital the startup receives. The authors of the study therefore concluded that patents are an effective protective mechanism for a startup's market position.

The study also found that AM startups should focus on B2B marketing because businesses tend to be more focused on long-term relationships, whereas individual consumers are not. Moreover, AM technology has a long history in B2B markets meaning that less marketing and communication effort is required to convince customers to buy a product.

A further important finding shared in the white paper is that application-based startups have the highest success rates in the AM sector. In contrast, startups in the materials space have the highest survival rate and software startups are the most likely to go out of business. The study highlights that AM Ventures has seen a major shift in its startup database as the number of application-based startups has increased significantly. In 2019, only 27% of AM Ventures' total pool of startups

(220) were application-based companies, and this number increased considerably by 2021, when 47% of the total startups (840) focused on AM applications. This major shift shows that the technology is approaching industrial maturity and mass production scenarios can be expected in the long term. Applications justify the existence of AM.

AM Ventures' research also found that there is no statistical correlation between the region in which the startup originates and its likelihood of success. While the business model design chosen by a startup may have originally been considered a valuable resource, the white paper reports no significant correlation between the choice of business model and success. However, a closer look at the hotspots and the business model used may reveal a statistical correlation. Further research is already underway.

## Conclusions

Companies have continued to integrate AM into their production processes to mitigate supply chain risks, increase flexibility in product design, and reduce manufacturing costs. Start-ups are playing a crucial role in the development of 3D printing technology and end users are advised to keep an eye on the space as there are opportunities for emerging and future applications to achieve real scale.

On the other hand, the speed of innovation among start-ups in the AM space is expected to continue to increase the momentum of the AM market in the coming year. Start-ups in AM are advised to learn from other regulated industries, where early certification of promising materials, design approaches, and technologies can provide start-ups with a competitive advantage by removing potential bottlenecks to adoption.

For more information:

Vito Chinellato - [chinellatovito@gmail.com](mailto:chinellatovito@gmail.com)

Alois Hotter - [ajh@amventures.com](mailto:ajh@amventures.com)

Alexander Schmoekkel - [as@amventures.com](mailto:as@amventures.com)

## About AM Ventures

The leading venture capital firm in industrial 3D printing (additive manufacturing, AM) AM Ventures has backed 20+ successful companies in seven countries on three continents. The team possesses in-depth technology know-how and is well connected with the most experienced experts in the field.

As an investment partner, the company provides a globally leading ecosystem of sustainable investments in AM and introduces entrepreneurs to a large pool of industry veterans offering decades of experience in engineering, manufacturing, and executive management. In 2021, AM Ventures was set up as a venture capital fund. Visit [www.amventures.com](http://www.amventures.com).



# ASSOCIAZIONE ITALIANA DI METALLURGIA

## POWDER METALLURGY AND ADDITIVE MANUFACTURING STUDY GROUP

Since its creation in 1959, the study group Powder Metallurgy has an active role in the dissemination of the knowledge of PM technology and in the promotion of the application of the sintered materials.

Starting from 2017, the study group changed its name in Powder Metallurgy and Additive Manufacturing.

Since 2019, the Group has been chaired by Eng. Ilaria Rampin, Sales Director Pometon Spa.

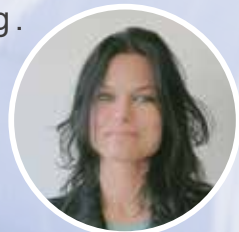

ASSOCIAZIONE  
ITALIANA DI  
METALLURGIA

La  
**Metallurgia**  
Italiana International Journal of the  
Italian Association for Metallurgy

[www.aimnet.it](http://www.aimnet.it)

